

No Nonsense Technician Class License Study Guide

for tests given between July 2026 and June 2030

Dan Romanchik KB6NU

Copyright © 2026 Daniel M. Romanchik

All rights reserved. No part of this publication may be reproduced, stored in a retrieval system, or transmitted in any form or by any means, electronic, mechanical, recording or otherwise, without the prior written permission of the author.

Revision 0, April 30, 2026

Table of Contents

What is amateur (ham) radio?	1
Electrical principles	4
Electronic components and circuits	19
Radio wave characteristics	34
Antennas and feed lines	45
Amateur radio signals	56
Amateur radio station safety	63
Station setup and operating controls	72
Station equipment	79
Operating procedures	88
Rules and regulations	103
Glossary	119
About the Author	122

What is amateur (ham) radio?

Amateur radio, also known as ham radio, is a hobby enjoyed by hundreds of thousands of Americans and millions around the world. They enjoy communicating with one another via two-way radios and experimenting with antennas and electronic circuits.

All kinds of people are amateur radio operators, also known as “hams.” Hams are young, old, men, women, boys and girls. Kids as young as seven years old have gotten amateur radio licenses, and many hams are active into their eighties and beyond. You never know who you'll run into on the amateur radio bands: young and old, teachers and students, engineers and scientists, doctors and nurses, mechanics and technicians, kings and entertainers.

For example, did you know that most of the astronauts sent up to the International Space Station (ISS) in the last five to ten years have been licensed radio amateurs? They use the amateur radio station on board the ISS to communicate with school groups all over the world as they are flying over.

How do you get into amateur radio?

With just a little study, you can learn all you need to know to get a Technician Class license, which is the license class designed for beginners. To get a Technician Class license, you must take a test with 35 multiple-choice questions and answer 26 questions correctly. The test covers basic regulations, operating practices, and electrical and electronics theory.

Knowing Morse Code is no longer required to get an amateur radio license. This makes it even easier to become a ham.

Technician Class licensees have all amateur radio privileges above 30 MHz, including the very popular 2-meter band. Technicians can also operate Morse Code (CW) on portions of the 80m, 40m, 15m, and 10m bands, and voice and digital modes on portions of the 10m band.

There are two other license classes: the General Class license and the Amateur Extra Class license. To get a General Class license, you must pass another 35-question test; the Amateur Extra Class test has 50 questions. The tests are progressively more difficult.

General Class licensees get phone and digital mode privileges on portions of the 160m, 80m, 60m, 40m, 20m, 17m, 15m, 12m, and 10m bands. They can also operate CW and digital modes on the 30m band. Amateur Extra licensees have all amateur privileges.

How much does it cost?

Basic study materials, such as this study guide, can be had for free, and the license exam fee will be \$15 or less. In addition, the FCC charges a \$35 license fee. You pay this amount after you pass the test.

Once you have your first license, most hams find it best to start with simple equipment and grow over time. A handheld VHF FM transceiver can be purchased for less than \$100 new, and excellent used equipment is often available at low prices. All things considered, the cost to get the first license and radio should be less than \$200.

Where do I take the test?

Amateur radio license examinations are given by Volunteer Examiners, or VEs. VEs are licensed radio amateurs who have been trained to administer amateur radio tests. To find out when the VEs in your area will be giving the test, go to the American Radio Relay League's (ARRL) website: <http://www.arrl.org/find-an-amateur-radio-license-exam-session>. Using that page, you will be able to search for test sessions that are close to you. If you do not have access to the Internet, you can phone the ARRL at 860-594-0200.

Can I really learn how to be an amateur radio operator from a study guide like this?

Yes and no. This manual will help you get your license, but getting your license is only the beginning. There is still much to learn, and to get the most out of amateur radio, you will have to continually learn new things.

This study guide will teach you the answers to the test questions, but will not give you a deep understanding of electronics, radio, or the rules and regulations. That will be up to you after you get your license.

I hope that, by helping you get your license, this guide will encourage you to become an active radio amateur and get on the air, participate in public service and emergency communications, join an amateur radio club, and experiment with radios, antennas, and circuits. These are the activities that will really help you learn about radio in depth, and in the end, help you be confident in your abilities as an amateur radio operator.

How do I use this study guide?

First, read through the study guide and then take some practice tests. In this version of the study guide, question and the correct answers are in bold-face type. The incorrect answers have been grayed out. You can take practice tests by going to the following websites:

- AA9PW.com
- QRZ.com/hamtest/
- eHam.net/exams/ (<http://eham.net/exams/>)
- HamExam.org (<http://hamexam.org>)
- HamStudy.org (<http://hamstudy.org>)

There are also ham test apps for both iOS and Android tablets:

- iOS:
 - Amateur Radio Exam Prep (<https://itunes.apple.com/us/app/amateur-radio-exam-prep-technician/id297951496?mt=8>). \$4.99
 - Ham Radio Exam (<https://itunes.apple.com/us/app/ham-radio-exam-tech/id601991935?mt=8>). FREE.

- Android:
 - Ham Radio Study (<https://play.google.com/store/apps/details?id=com.tango11.hamstudy>)
 - Ham Test Prep (<https://play.google.com/store/apps/details?id=com.iversoft.ham.test.prep&hl=en>)

Many of the questions use terms with which you may be unfamiliar. In the glossary, you will find definitions of those terms. Please refer to the glossary if you are unsure of the meaning of an acronym.

Good luck and have fun

I hope that you find this study guide useful and that you'll become a radio amateur. Remember that getting your license is just a start and that you will continue to learn new things.

If you have any comments, questions, compliments or complaints, I want to hear from you. E-mail me at cwgeek@kb6nu.com. My goal is to continually refine and improve this study guide.

73!

Dan Romanchik KB6NU

Electrical principles

Units and terms: current, voltage, and resistance; alternating and direct current; conductors and insulators

Electricity is central to everything we do in amateur radio. Whether it comes from a battery or a wall socket, electricity is what enables us to transmit and receive radio waves. To understand how radio works, you need to understand how electrical circuits work.

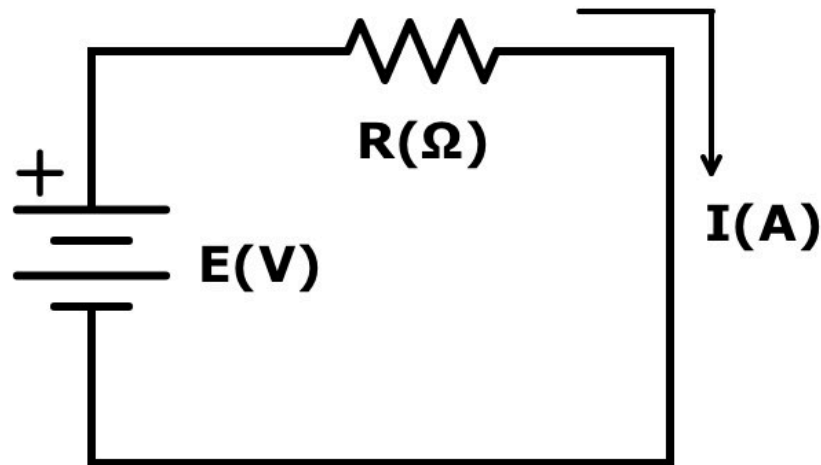

Figure 1-1. A simple electric circuit.

Figure 1 shows a simple electrical circuit.

The battery provides the push for electrons to flow through the circuit. We call this force electromotive force (E), and we measure electromotive force in *volts* (V). Think of it like water pressure in a hose. Just as water pressure pushes water through a hose, voltage pushes electrons through a circuit. The battery creates a voltage difference between its positive and negative terminals, which cause electrons to flow when the battery is connected to a circuit.

We call this flow of electrons *current*. In Figure 1, the letter I stands for current. Current flows from the positive (+) terminal of the battery through the circuit to the negative terminal of the battery. Current is measured in amperes, and we use the letter A to stand for amperes.

T5A05

A difference in which of the following causes electron flow?

- A. **Voltage**
- B. Ampere-hours
- C. Capacitance
- D. Inductance

T5A03

What is the name for the flow of electrons in an electric circuit?

- A. Voltage
- B. Amperes per second
- C. Volts per second
- D. **Current**

T5A01

Electrical current is measured in which of the following units?

- A. Volts
- B. Watts
- C. Ohms
- D. **Amperes**

Resistance opposes the flow of current in a circuit. You can think of resistance as a kink in the hose that restricts the flow of water. The higher the resistance, the smaller the current, for a given voltage difference, and vice versa.

In Figure 1-1, we use the letter R (and the symbol above it) to stand for resistance. Resistance is measured in ohms, and we use the Greek letter omega (Ω) to stand for ohms. An important thing to remember about resistance is that all types of current—including direct current, alternating current, and radio frequency (RF) current—are opposed by resistance. We'll discuss alternating current and RF current later in this study guide.

T5A11

What type of current flow is opposed by resistance?

- A. Direct current
- B. Alternating current
- C. RF current
- D. **All these choices are correct**

Because the polarity of the battery voltage in the circuit never changes, the current will flow in only one direction through the circuit. We call this direct current, or DC. Batteries supply direct current, or simply, DC.

The type of current you get out of a wall socket is different from the current that you get from a battery. We call it alternating current, or AC, because the voltage and current are constantly changing. Figure 1-2 shows how the voltage of an alternating current waveform changes with time. For this particular waveform, the voltage starts at 0 V, increases to a positive peak voltage, then decreases to a negative peak voltage, and then begins increasing again, until it once again reaches 0 V. When the voltage is positive, the current flows in one direction, and when the voltage is negative the current flows in the opposite direction. This process repeats over and over.

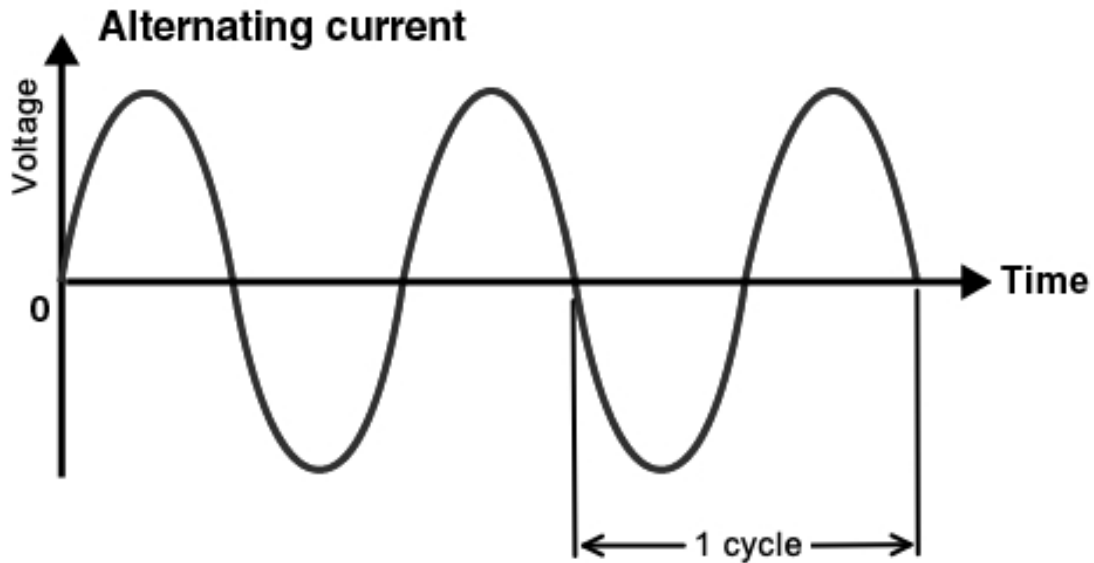

Figure 1-2. Alternating current waveform.

T5A09

Which of the following describes alternating current?

- A. Current that alternates between a positive direction and zero
- B. Current that alternates between a negative direction and zero
- C. **Current that alternates between positive and negative directions**
- D. All these answers are correct

One of the most important parameters of an alternating current is its frequency. The frequency of an alternating current is the number of times per second that an alternating current makes a complete cycle, where a cycle is the portion of an alternating current waveform that repeats over and over. See Figure 2.

The frequency of the alternating current that you get from a wall socket in your home is 60 cycles per second, or in engineering terms, 60 hertz (Hz). 1 Hz is equal to one cycle per second.

T5A04

What term describes the number of times per second that an alternating current makes a complete cycle?

- A. Pulse rate
- B. Wave number
- C. **Frequency**
- D. Wavelength

T5A06

What is the unit of frequency?

- A. **Hertz**
- B. Henry
- C. Farad
- D. Epicycles per second

To connect components in an electric circuit, we generally use metal wires because they conduct electrical current well or, in other words, have a low resistance. Metals generally are good conductors because they have many free electrons, and as a result, offer low resistance to current flow. Copper is generally the conductor of choice for electronic cables and circuits because it offers good conductivity and costs less than silver or gold.

T5A07

Why are metals generally good conductors of electricity?

- A. They have relatively high density
- B. **They have many free electrons**
- C. They have many free protons
- D. They have relatively high Young's modulus values

Many times we need a material that does not conduct current very well. We call these materials insulators, and insulators have a high resistance. Plastics and glass are commonly used insulators.

T5A08

Which of the following is a good electrical insulator?

- A. Sea water
- B. **Glass**
- C. Stainless steel
- D. Graphite

Ohm's Law: formulas and usage

Hams obey Ohm's Law!

Ohm's Law is the relationship between voltage, current, and resistance in an electrical circuit. When you know any two of these values, you can calculate the third.

The most basic equation for Ohm's Law is $E = I \times R$. In other words, when you know the current (I) flowing through a circuit and the resistance (R) of the circuit, you can calculate the voltage (E) across the circuit by multiplying these two values.

T5D02

What formula is used to calculate voltage in a circuit?

A. $E = I \times R$

B. $E = I / R$

C. $E = I^2 \times R$

D. $E = I^2 / R$

Using simple algebra, you can derive the other two forms of this equation: $R = E / I$ and $I = E / R$. These two equations let you calculate the resistance in a circuit if you know the voltage and current or the current in a circuit if you know the voltage and resistance.

T5D03

What formula is used to calculate resistance in a circuit?

A. $R = E \times I$

B. $R = E / I$

C. $R = E + I$

D. $R = E - I$

T5D01

What formula is used to calculate current in a circuit?

A. $I = E \times R$

B. $I = E / R$

C. $I = E^2 \times R$

D. $I = E^2 / R$

Now, let's look at some examples of how to apply Ohm's Law.

T5D04

What is the resistance of a circuit in which a current of 3 amperes flows when connected to 90 volts?

A. 3 ohms

B. **30 ohms**

C. 1/30 ohm

D. 270 ohms

Here's how to calculate this answer: $R = E / I = 90 \text{ volts} / 3 \text{ amperes} = 30 \text{ ohms}$.

T5D05

What is the resistance of a circuit for which the applied voltage is 12 volts and the current flow is 1.5 amperes?

- A. 18 ohms
- B. 0.125 ohms
- C. 8 ohms**
- D. 13.5 ohms

$$R = E / I = 12 \text{ volts} / 1.5 \text{ amperes} = 8 \text{ ohms.}$$

T5D06

What is the resistance of a circuit that draws 4 amperes from a 12-volt source?

- A. 3 ohms**
- B. 16 ohms
- C. 48 ohms
- D. 8 ohms

$$R = E / I = 12 \text{ volts} / 4 \text{ amperes} = 3 \text{ ohms.}$$

Now, let's look at another form of the Ohm's Law equation, $I = E / R$ to calculate the current in a circuit.

T5D07

What is the current in a circuit with an applied voltage of 120 volts and a resistance of 80 ohms?

- A. 9600 amperes
- B. 200 amperes
- C. 0.667 amperes
- D. 1.5 amperes**

$$I = E / R = 120 \text{ volts} / 80 \text{ ohms} = 1.5 \text{ amperes.}$$

T5D08

What is the current through a 100-ohm resistor connected across 200 volts?

- A. 20,000 amperes
- B. 0.5 amperes
- C. 2 amperes**
- D. 100 amperes

$$I = E / R = 200 \text{ volts} / 100 \text{ ohms} = 2 \text{ amperes.}$$

T5D09

What is the current through a 24-ohm resistor connected across 240 volts?

- A. 2400 amperes
- B. 0.1 amperes
- C. 10 amperes**
- D. 5760 amperes

$$I = E / R = 240 \text{ volts} / 24 \text{ ohms} = 10 \text{ amperes.}$$

Now, let's look at the third form of the Ohm's Law equation, $E = I \times R$ to calculate the voltage across a cir-

cuit.

T5D10

What is the voltage across a 2-ohm resistor if a current of 0.5 amperes flows through it?

- A. **1 volt**
- B. 0.25 volts
- C. 2.5 volts
- D. 1.5 volts

$$E = I \times R = 0.5 \text{ amperes} \times 2 \text{ ohms} = 1 \text{ volt.}$$

T5D11

What is the voltage across a 10-ohm resistor if a current of 1 ampere flows through it?

- A. 1 volt
- B. **10 volts**
- C. 11 volts
- D. 9 volts

$$E = I \times R = 1 \text{ amperes} \times 10 \text{ ohms} = 10 \text{ volts.}$$

T5D12

What is the voltage across a 10-ohm resistor if a current of 2 amperes flows through it?

- A. 8 volts
- B. 0.2 volts
- C. 12 volts
- D. **20 volts**

$$E = I \times R = 2 \text{ amperes} \times 10 \text{ ohms} = 20 \text{ volts.}$$

Series and parallel circuits

Now, let's consider circuits with two resistors instead of just a single resistor. There are two ways in which the two resistors can be connected: in series or in parallel. Figure 1-3 shows a series circuit.

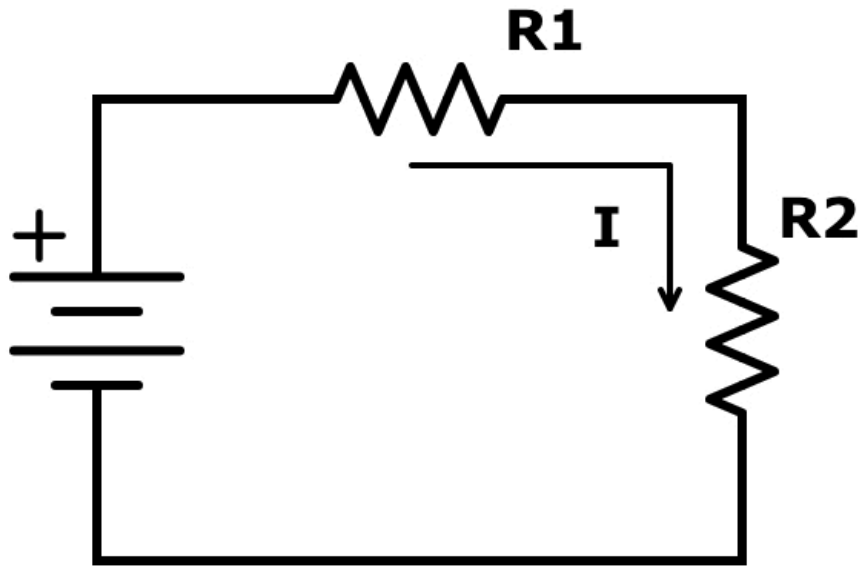

Figure 1-3. A series circuit.

The current I flows through both resistors because there is only one path for the current to flow. If $R_1 = R_2$, then the voltage will be the same across both resistors, because the same current flows through both resistors. If R_1 does not equal R_2 , however, the voltages will be different. In either case, the sum of the two voltages will equal the voltage of the voltage source.

T5D13

In which type of circuit is the current always the same through all components?

- A. **Series**
- B. Parallel
- C. Resonant
- D. Branch

In a parallel circuit, shown in Figure 1-4, both resistors are connected directly to the voltage source.

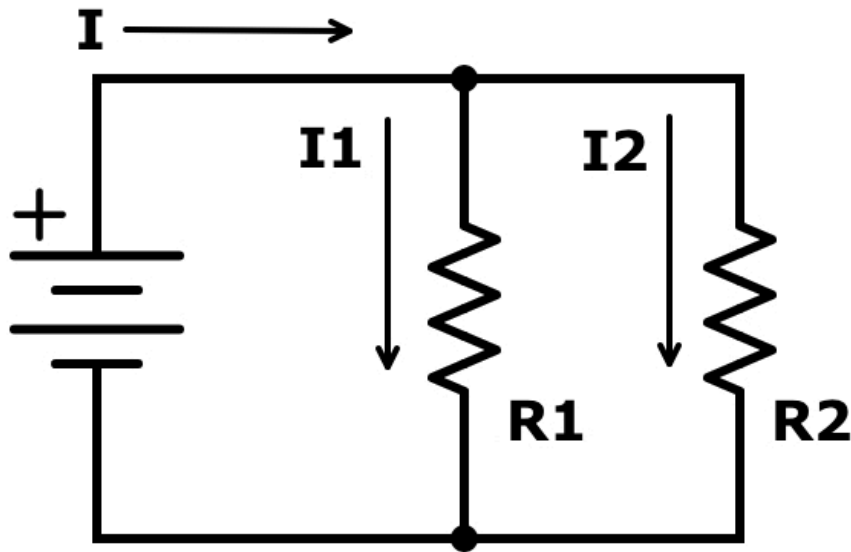

Figure 4. A parallel circuit.

Because both components are connected directly to the voltage source, the voltage across them will be the same. This voltage will cause currents to flow in each of the resistors. $I_1 = E/R_1$, and $I_2 = E/R_2$. The total current, I , is equal to $I_1 + I_2$. If $R_1 = R_2$, then the same current flows through both resistors. If the resistors have different values, then I_1 will be different from I_2 .

T5D14

In which type of circuit is voltage the same across all components?

- A. Series
- B. Parallel**
- C. Resonant
- D. Branch

DC power

Power is the rate at which electrical energy is generated or used and is measured in watts. We use the letter P to stand for power and the letter W to stand for watts.

T5A10

Which term describes the rate at which electrical energy is used?

- A. Resistance
- B. Current
- C. **Power**
- D. Voltage

T5A02

Electrical power is measured in which of the following units?

- A. Volts
- B. **Watts**
- C. Watt-hours
- D. Amperes

A typical LED light bulb has a rating of 9 watts, while producing a similar amount of light that a 60-watt incandescent bulb would produce. In other words, the LED bulb uses less than $1/6$ the power of the incandescent bulb.

To calculate power, we multiply the current flowing through the circuit by the voltage across the circuit. We write this equation $P = I \times E$.

T5C08

What is the formula used to calculate electrical power (P) in a DC circuit?

- A. **$P = I \times E$**
- B. $P = E / I$
- C. $P = I^2 \times E$
- D. $P = I / E$

Here are some examples:

T5C09

How much power is delivered by a voltage of 13.8 volts DC and a current of 10 amperes?

- A. **138 watts**
- B. 0.7 watts
- C. 23.8 watts
- D. 3.8 watts

The calculation for this question is $P = E \times I = 13.8 \text{ V} \times 10 \text{ A} = 138 \text{ W}$.

T5C10

How much power is delivered by a voltage of 12 volts DC and a current of 2.5 amperes?

- A. 4.8 watts
- B. **30 watts**
- C. 14.5 watts
- D. 0.208 watts

The calculation for this question is $P = E \times I = 12 \text{ V} \times 2.5 \text{ A} = 30 \text{ W}$.

Just as with Ohm's Law, you can use algebra to come up with other forms of this equation to calculate the voltage if you know the power and the current, or to calculate the current if you know the power and the voltage. The formula to calculate the current, if you know the power and the voltage, is $I = P / E$.

T5C11

How much current is required to deliver 120 watts at a voltage of 12 volts DC?

- A. 0.1 amperes
- B. 10 amperes**
- C. 12 amperes
- D. 132 amperes

The calculation for this question is $I = P / E = 120 \text{ W} / 12 \text{ V} = 10 \text{ A}$.

Math for electronics and conversion of electrical units

When dealing with electrical parameters such as voltage, resistance, current, and power, we use a set of prefixes to denote various orders of magnitude:

- milli- is the prefix used to denote 1 one-thousandth of a quantity. A milliampere, for example, is 1 one-thousandth of an ampere, or 0.001 A. Often, the letter m is used instead of the prefix milli-. 1 milliampere is, therefore, 1 mA.
- micro- is the prefix used to denote 1 one-millionth of a quantity. A microvolt, for example, is 1 one-millionth of a volt, or 0.000001 V. Often, you will see the Greek letter mu, or μ , used to denote the prefix micro-. 1 microvolt is, therefore, 1 μ V.
- pico- is the prefix used to denote 1 one-trillionth of a quantity. A picovolt is 1 one-trillionth of a volt, or 0.000001 μ V.
- kilo- is the prefix used to denote 1 thousand of a quantity. A kilovolt, for example, is 1000 volts. Often, the letter k is used instead of the prefix kilo-. 1 kilovolt is, therefore, 1 kV.
- mega- is the prefix used to denote 1 million of a quantity. A megahertz, for example, is 1 million Hertz. Often, the letter M is used instead of the prefix mega-. 1 megahertz is, therefore, 1 MHz.
- giga - is the prefix used to denote one billion of a quantity. One gigahertz, or 1 GHz, for example is 1 billion Hertz.

Prefix	Abbreviation	Numerical	Exponential
giga-	G	1,000,000,000	10^9
mega-	M	1,000,000	10^6
kilo-	k	1,000	10^3
----	----	1	10^0
milli-	m	0.001	10^{-3}
micro-	μ ,u	0.000001	10^{-6}
nano-	n	0.000000001	10^{-9}
pico-	p	0.000000000001	10^{-12}

On the test, you will be asked convert quantities from one unit to another. The first question, for example, asks you to convert a quantity from amperes to milliamperes.

T5B01

How many milliamperes is 1.5 amperes?

- A. 0.0000015 milliamperes
- B. 0.0015 milliamperes
- C. 1500 milliamperes**
- D. 1,500,000 milliamperes

To convert amperes to milliamperes, you multiply by 1,000.

T5B02

Which is equal to 1,500,000 hertz?

- A. 1500 kHz**
- B. 1500 MHz
- C. 15 GHz
- D. 150 kHz

To convert from hertz (Hz) to kHz, you divide by 1,000.

T5B03

Which is equal to one kilovolt?

- A. One one-thousandth of a volt
- B. One hundred volts
- C. One thousand volts**
- D. One million volts

T5B04

Which is equal to one microvolt?

- A. One one-millionth of a volt**
- B. One million volts
- C. One thousand kilovolts
- D. One one-thousandth of a volt

To convert from kilovolts to volts, you multiply by 1,000. To convert from microvolts to volts, you divide by one million.

T5B05

Which is equal to 500 milliwatts?

- A. 5 watts
- B. 0.5 watts**
- C. 500,000 watts
- D. 500,000,000 watts

To convert from milliwatts to watts, you divide by 1,000. $500 / 1000 = \frac{1}{2}$ or 0.5.

T5B06

Which is equal to 3000 milliamperes?

- A. 0.003 amperes
- B. 0.3 amperes
- C. 3,000,000 amperes
- D. 3 amperes**

There are a thousand milliamperes in an ampere, so to convert from milliamperes to amperes, you divide by 1,000.

T5C06

What is the abbreviation for kilohertz?

- A. **kHz**
- B. khz
- C. KHz
- D. KHZ

1 kHz is 1,000 Hz or 1,000 cycles per second. Note that the “H” in Hz is capitalized. 1,000,000 cycles per second is 1,000 kHz, or 1 MHz.

T5C07

What is the abbreviation for megahertz?

- A. mHz
- B. mHZ
- C. Mhz
- D. **MHz**

T5B07

Which is equal to 3.525 MHz?

- A. 0.003525 kHz
- B. 35.25 kHz
- C. **3525 kHz**
- D. 3,525,000 kHz

T5B12

Which is equal to 28400 kHz?

- A. 28.400 kHz
- B. 2.800 MHz
- C. 284.00 MHz
- D. **28.400 MHz**

T5B13

Which is equal to 2425 MHz?

- A. 0.002425 GHz
- B. 24.25 GHz
- C. **2.425 GHz**
- D. 242.5 GHz

To convert from MHz to kHz, you multiply by 1,000. To convert from kHz to MHz, or to convert from MHz to GHz, you divide by 1,000.

The farad is the unit of capacitance. There are 1 million picofarads in a microfarad.

T5B08

Which is equal to 1,000,000 picofarads?

- A. 0.001 microfarads
- B. **1 microfarad**
- C. 1000 microfarads
- D. 1,000,000,000 microfarad

Decibels

When dealing with ratios—especially power ratios—we often use decibels (dB). The reason for this is that the decibel scale is a logarithmic scale, meaning that we can talk about large ratios with relatively small numbers. When the value is positive, it means that there is a power increase. When the value is negative, it means that there is a power decrease.

At this point, you don't need to know the formula used to calculate the ratio in dB, but you need to know the ratios represented by the values 3 dB, 6 dB, and 10 dB. 3 dB corresponds to a power ratio of 2 to 1, 6 dB corresponds to a power ratio of 4 to 1, and 10 dB corresponds to a power ratio of 10 to 1.

T5B09

Which decibel value most closely represents a power increase from 5 watts to 10 watts?

- A. 2 dB
- B. 3 dB**
- C. 5 dB
- D. 10 dB

3 dB corresponds to a ratio of 2 to 1, and because going from 5 watts to 10 watts doubles the power, we can also say that there is a gain of 3 dB.

T5B10

Which decibel value most closely represents a power decrease from 12 watts to 3 watts?

- A. -1 dB
- B. -3 dB
- C. -6 dB**
- D. -9 dB

6 dB corresponds to a ratio of 4 to 1, and a decrease in power from 12 watts to 3 watts is a ratio of 4 to 1. Because this is a power decrease, the value in dB is negative.

T5B11

Which decibel value represents a power increase from 20 watts to 200 watts?

- A. 10 dB**
- B. 12 dB
- C. 18 dB
- D. 28 dB

Increasing the power from 20 watts to 200 watts is a ratio of 10 to 1, and 10 dB corresponds to a ratio of 10 to 1.

Electronic components and circuits

Resistors

Resistors are components that, as the name implies, oppose the flow of current. We use them to control how much current flows in a circuit. The higher the resistance, the lower the current.

Most resistors have a fixed value, specified in ohms, but some are designed to be variable. That is, you can change the resistance by turning a shaft or sliding a control back and forth. Variable resistors, also called potentiometers, are often used to allow users to adjust the way a device operates.

T6A01

What electrical component opposes the flow of current in a DC circuit?

- A. Inductor
- B. Resistor**
- C. Inverter
- D. Transformer

T6A02

What type of component is often used as an adjustable volume control?

- A. Fixed resistor
- B. Power resistor
- C. Potentiometer**
- D. Transformer

T6A03

What electrical parameter is controlled by a potentiometer?

- A. Inductance
- B. Resistance**
- C. Capacitance
- D. Field strength

Capacitors

Another common electrical component is the capacitor. The most basic type of capacitor consists of two metal plates separated by an insulator, called a dielectric. When you put a DC voltage across a capacitor, an electric current flows into the capacitor until the voltage across the capacitor equals the DC voltage. This puts a positive charge on one plate and a negative charge on the other, thereby creating an electric field between the two plates.

T6A05

What type of electrical component consists of conductive surfaces separated by an insulator?

- A. Resistor
- B. Potentiometer
- C. Oscillator
- D. **Capacitor**

T6A04

What electrical component stores energy in an electric field?

- A. Resistor
- B. **Capacitor**
- C. Inductor
- D. Diode

The capacitor stores energy in that electric field. The ability to store energy in an electric field is called capacitance, and the unit of capacitance is called the farad.

T5C01

What describes the ability to store energy in an electric field?

- A. Inductance
- B. Resistance
- C. Frequency
- D. **Capacitance**

T5C02

What is the unit of capacitance?

- A. **Farad**
- B. Ohm
- C. Volt
- D. Henry

Inductors

The third most common type of electrical component in amateur radio equipment is the inductor. Inductors are usually small coils of wire, and when a current flows through that coil of wire, a magnetic field is set up around the coil.

T6A07

What electrical component is typically constructed as a coil of wire?

- A. Transistor
- B. Capacitor
- C. Diode
- D. **Inductor**

T6A06

What type of electrical component stores energy in a magnetic field?

- A. Resistor
- B. Capacitor
- C. **Inductor**
- D. Diode

An inductor stores energy in a magnetic field. The ability to do this is called inductance, and the unit of inductance is the henry.

T5C03

What describes the ability to store energy in a magnetic field?

- A. Admittance
- B. Capacitance
- C. Resistance
- D. **Inductance**

T5C04

What is the unit of inductance?

- A. Coulomb
- B. Farad
- C. **Henry**
- D. Ohm

Batteries

We often use batteries to power our radio equipment. Some types of batteries, such as nickel-metal hydride, lithium-ion, and lead-acid batteries, are rechargeable. Other types of batteries, such as carbon-zinc batteries, are not.

T6A10

Which of the following battery chemistries is rechargeable?

- A. Nickel-metal hydride
- B. Lithium-ion
- C. Lead-acid
- D. **All these choices are correct**

T6A11

Which of the following battery chemistries is not rechargeable?

- A. Nickel-cadmium
- B. **Carbon-zinc**
- C. Lead-acid
- D. Lithium-ion

Diodes

Diodes are the most basic semiconductor component. Diodes have two electrodes, called the anode and cathode, and allow current to flow only in one direction. When the voltage on the anode is positive with respect to the cathode, current will flow through the diode, but when the voltage on the anode is negative with respect to the cathode, the diode will block current. To identify identify a diode's cathode, it is often marked with a stripe.

T6B02

What electronic component allows current to flow in only one direction?

- A. Resistor
- B. Fuse
- C. Diode**
- D. Driven element

T6B09

What are the names for the electrodes of a diode?

- A. Plus and minus
- B. Source and drain
- C. Anode and cathode**
- D. Gate and base

T6B06

How is the cathode lead of a semiconductor diode often marked on the package?

- A. With the word "cathode"
- B. With a stripe**
- C. With the letter C
- D. With the letter K

When current is flowing through a diode, there is a voltage drop across the diode called the forward voltage drop. The value of the forward voltage drop is lower in some diodes than in others. For example, the forward voltage of a germanium diode is about 0.3 V, while the forward voltage drop in a silicon diode is about 0.7 V.

T6B01

Which is true about forward voltage drop in a diode?

- A. It is lower in some diode types than in others**
- B. It is proportional to peak inverse voltage
- C. It indicates that the diode is defective
- D. It has no impact on the voltage delivered to the load

Light-emitting diodes, or LEDs, are a particular type of diode. Forward DC current, that is current that flows from the anode to the cathode, causes LEDs to emit light, making them useful as visual indicators.

T6B07

What causes a light-emitting diode (LED) to emit light?

- A. Forward DC current**
- B. Reverse DC current
- C. Capacitively-coupled RF signal
- D. Inductively-coupled RF signal

T6D07

Which of the following is commonly used as a visual indicator?

A. **LED**

B. FET

C. Zener diode

D. All these choices are correct

Transistors

Transistors are semiconductor components designed to control the current flow through them. They have three leads and one of those leads is used as the control pin. A current, in the case of the bipolar junction transistor, or a voltage, in the case of the field effect transistor, on the control pin controls the current flow between the two other pins.

In some circuits, the transistor is used as a switch, and the control signal simply switches the current on and off. In other circuits, the transistor is used as an amplifier. When used as an amplifier, the current through the transistor is proportional to the input current or voltage. The ratio of output current to input current is called the gain of the transistor.

T6B03

Which of these components can be used as an electronic switch?

- A. Varistor
- B. Potentiometer
- C. Transistor**
- D. Thermistor

T6B10

Which of the following can provide power gain?

- A. Transformer
- B. Transistor**
- C. Reactor
- D. Resistor

T6B11

What does the term gain mean in amplifiers?

- A. The output signal voltage relative to the input signal voltage
- B. The output signal current relative to the input signal current
- C. The output signal power relative to the input signal power
- D. All these choices are correct**

Bipolar junction transistors are transistors that consist of three regions of semiconductor material. These regions are either P-type, which means that it has a positive net charge, or N-type, which means it has a net negative charge. Each region has an electrode, making the transistor a device with three leads. The names of these three electrodes are emitter, base and collector.

There are two types of bipolar junction transistors: PNP or NPN. A PNP transistor has two P layers, with an N layer sandwiched between them. An NPN transistor has two N layers, with a P layer sandwiched between them.

T6B04

Which of the following components can consist of three regions of semiconductor material?

- A. Alternator
- B. Transistor**
- C. Triode

D. Pentode

T6B12

What are the names of the electrodes of a bipolar junction transistor?

A. Signal, bias, power

B. Emitter, base, collector

C. Input, output, supply

D. Pole one, pole two, output

Another type of transistor often found in amateur radio equipment is the field-effect transistor, or FET. To control the flow of current through the field effect transistor, you use a voltage signal on the control pin. This voltage sets up an electric field inside the transistor, hence the name field effect transistor. FETs, like NPN and PNP transistors have three electrodes. These electrodes are called the gate, drain, and source.

T6B08

What does the abbreviation FET stand for?

A. Frequency Emission Transmitter

B. Fast Electron Transistor

C. Free Electron Transmitter

D. Field Effect Transistor

T6B05

What type of transistor has a gate, drain, and source?

A. Varistor

B. Field-effect

C. Hall-effect

D. Bipolar junction

Circuit diagrams, schematic symbols, component functions

Schematics are electrical wiring diagrams that use standard component symbols represent an electrical or electronic circuit. They show the components used in a circuit and how they are connected. If someone gave you a schematic diagram and all of the components shown on the diagram, you could actually build the circuit. Figure T-1 is an example of a schematic diagram.

T6C01

What is the name of an electrical wiring diagram that uses standard component symbols?

- A. Connection chart
- B. Instrumentation system
- C. **Schematic**
- D. Flow chart

T6C12

Which of the following is accurately represented in electrical schematics?

- A. Wire lengths
- B. Physical appearance of components
- C. **Component connections**
- D. All these choices are correct

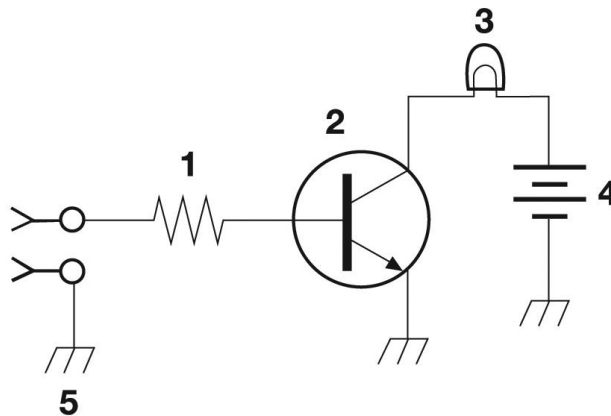

Figure T-1

Figure T-1 is a schematic diagram of a simple transistor circuit. In this circuit, the transistor (component #2) is used as a switch that turns on a lamp (#3) when a positive voltage is applied to the input. The positive voltage on the transistor input enables the transistor to conduct current supplied by the battery (#4) through the lamp, and the current causes the lamp to glow.

T6C02

What is component 1 in figure T-1?

- A. **Resistor**
- B. Transistor
- C. Battery

D. Connector

T6C03

What is component 2 in figure T-1?

- A. Resistor
- B. Transistor**
- C. Indicator lamp
- D. Connector

T6D10

What is the function of component 2 in figure T-1?

- A. Give off light when current flows through it
- B. Supply electrical energy
- C. Control the flow of current**
- D. Convert electrical energy into radio waves

T6C04

What is component 3 in figure T-1?

- A. Resistor
- B. Transistor
- C. Lamp**
- D. Ground symbol

T6C05

What is component 4 in figure T-1?

- A. Resistor
- B. Transistor
- C. Ground symbol
- D. Battery**

The circuit shown in Figure T2 is a simple power supply. Component 1 is a plug that is plugged into a wall socket. Component 2 is a fuse, and component 3 is a single-pole, single throw switch that is being used as the on-off switch.

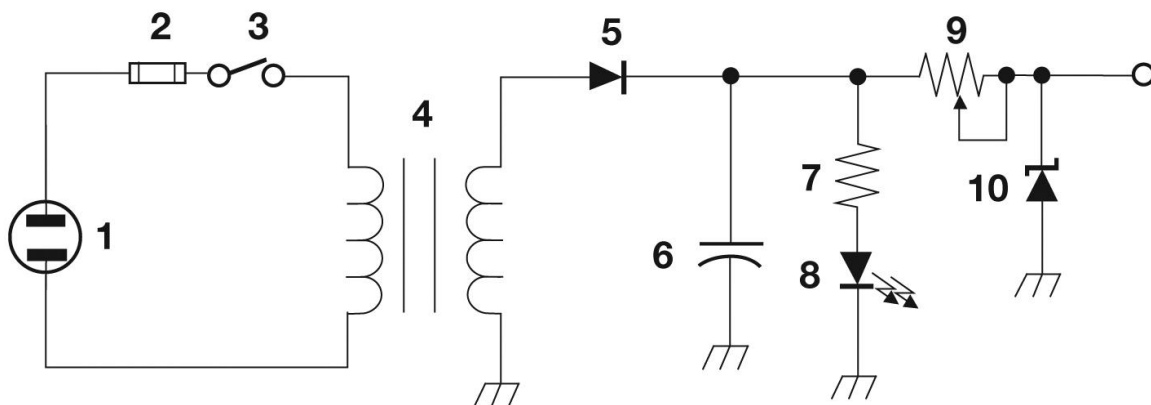

Figure T-2

T6A09

What type of switch is represented by component 3 in figure T-2?

- A. **Single-pole single-throw**
- B. Single-pole double-throw
- C. Double-pole single-throw
- D. Double-pole double-throw

Component 4 in Figure T-2 is a transformer. It converts the 120 VAC input to a lower AC voltage for other uses. If this power supply was going to be used to power amateur radio equipment, the transformer output would probably be between 12 VAC and 15 VAC.

T6C09

What is component 4 in figure T-2?

- A. Variable inductor
- B. Double-pole switch
- C. Potentiometer
- D. **Transformer**

T6D06

What component changes 120 V AC power to a lower AC voltage for other uses?

- A. Variable capacitor
- B. **Transformer**
- C. Transistor
- D. Diode

Component 5 in Figure T2 is a diode. Diodes allow current to flow only in one direction, so it converts the alternating current output of the transformer to a varying direct current. This process of changing an alternating current into a varying direct current signal is called rectification, and the devices or circuits that perform rectification, such as the diode in this circuit, are called *rectifiers*.

T6D01

Which of the following devices or circuits changes an alternating current into a varying direct current signal?

- A. Transformer
- B. **Rectifier**
- C. Amplifier
- D. Reflector

Component 6 in Figure T-2 is a capacitor. Its job is to filter out remnants of the 60 Hz AC that are part of the varying direct current signal. That's why a capacitor used this way is sometimes called a filter capacitor.

T6C06

What is component 6 in figure T-2?

- A. Resistor
- B. **Capacitor**
- C. Regulator IC
- D. Transistor

Component 8 in Figure T-2 is an LED. The LED is a pilot light, serving to alert a user when the power

supply is on.

T6C07

What is component 8 in figure T-2?

- A. Resistor
- B. Inductor
- C. Regulator IC
- D. **Light emitting diode**

Component 9 in Figure T-2 is a variable resistor. Whenever you see a schematic symbol with an arrow through it or pointing to it, it means that the component has a variable value.

T6C08

What is component 9 in figure T-2?

- A. Variable capacitor
- B. Variable inductor
- C. **Variable resistor**
- D. Variable transformer

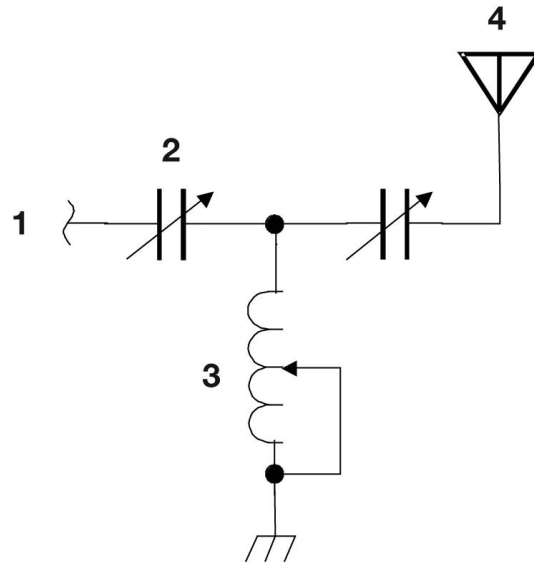

Figure T-3

The circuit shown in Figure T3 is a type of antenna tuner.

T6C10

What is component 3 in figure T-3?

- A. Connector
- B. Meter
- C. Variable capacitor
- D. **Variable inductor**

T6C11

What is component 4 in figure T-3?

- A. **Antenna**
- B. Transmitter
- C. Dummy load
- D. Ground

Resonant, or tuned, circuits

When a circuit has both inductors and capacitors, we sometimes call it a resonant, or tuned circuit. The reason for this is that these circuits have a resonant frequency. When a capacitor and inductor are connected in series, the circuit has a very low impedance at the resonant frequency, and it will act almost like a short circuit. When the capacitor and inductor are connected in parallel, the circuit has a very high impedance at the resonant frequency, so it acts almost like an open circuit.

T6D11

Which of the following is a resonant or tuned circuit?

- A. **An inductor and a capacitor in series or parallel**
- B. A linear voltage regulator

- C. A resistor circuit used for reducing standing wave ratio
- D. A circuit designed to provide high-fidelity audio

T6D08

Which of the following is combined with an inductor to make a resonant circuit?

- A. Resistor
- B. Zener diode
- C. Potentiometer
- D. **Capacitor**

Other components

There are many different types of components in modern radio equipment. Below, we will describe the types of components you will need to know about to pass the Technician Class license examination.

Switches are used to open and close circuits or to switch an input or output between two or more circuits. A single-pole, dual-throw, or SPDT, switch connects a single circuit between two other circuits.

T6A08

What is the function of an SPDT switch?

- A. A single circuit is opened or closed
- B. Two circuits are opened or closed
- C. A single circuit is switched between one of two other circuits**
- D. Two circuits are each switched between one of two other circuits

Normally, switches are manually-controlled, such as the light switch in your home. Relays, however, are controlled electrically. Applying a voltage to the input of a relay causes its output to switch.

T6D02

What is a relay?

- A. An electrically-controlled switch**
- B. A current-controlled amplifier
- C. An inverting amplifier
- D. A pass transistor

Meters are devices used to indicate many different values. Meters can indicate the output voltage of a power supply, the output power of a transmitter, and many other values.

T6D04

Which of the following displays an electrical quantity as a numeric value?

- A. Potentiometer
- B. Transistor
- C. Meter**
- D. Relay

To make electronic circuits smaller, component manufacturers make devices that have many electronic components on a single piece of silicon. We call these integrated circuits. Integrated circuits, such as microprocessors, may have million of transistors inside them.

T6D09

What is the name of a device that combines several semiconductors and other components into one package?

- A. Transducer
- B. Multi-pole relay
- C. Integrated circuit**
- D. Transformer

Integrated circuits may perform either analog or digital functions. One type of analog integrated circuit that is very common is the voltage regulator.

T6D05

What type of circuit controls the amount of voltage from a power supply?

- A. **Regulator**
- B. Oscillator
- C. Filter
- D. Phase inverter

When connecting electronic assemblies together, we often use cables with one or more conductors. Some of those conductors may have a shield around them that is connected to ground.

T6D03

Which of the following is a reason to use shielded wire?

- A. To decrease the resistance of DC power connections
- B. To increase the current carrying capability of the wire
- C. **To prevent coupling of unwanted signals to or from the wire**
- D. To reduce receiver overload

Radio wave characteristics

Frequency, wavelength, and the electromagnetic spectrum

To be a successful radio amateur, you need to know some of the science behind radio waves, specifically how radio waves are generated and how they behave. Radio waves are electromagnetic radiation. That is to say that they consist of both electric and magnetic fields, and those field are at right angles to one another, as shown in Figure 3-1 below.

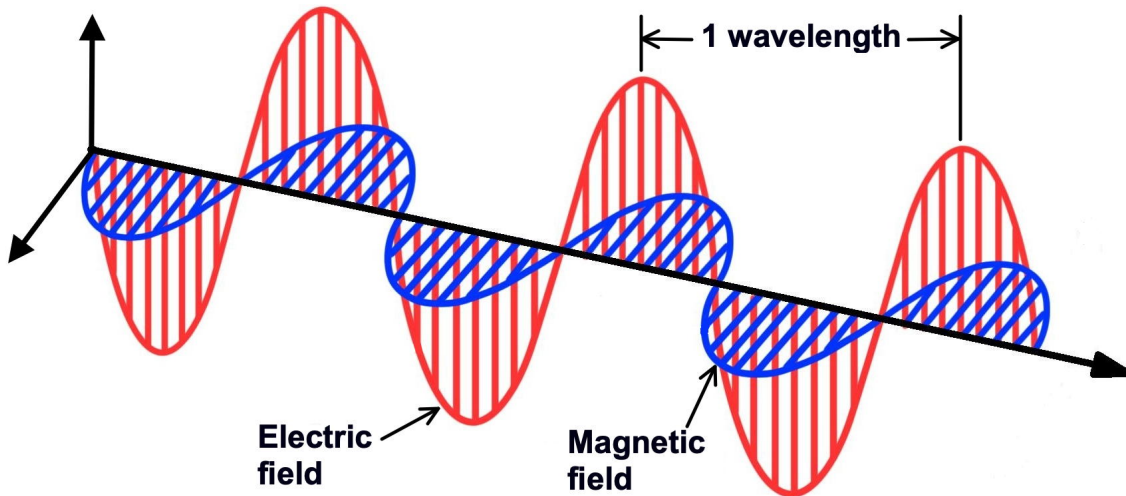

Figure 1-3. An electromagnetic wave.

T3B03

What are the two components of a radio wave?

- A. Impedance and reactance
- B. Voltage and current
- C. Electric and magnetic fields**
- D. Ionizing and non-ionizing radiation

T3B01

What is the relationship between the electric and magnetic fields of an electromagnetic wave?

- A. They travel at different speeds
- B. They are in parallel
- C. They revolve in opposite directions
- D. They are at right angles**

These fields are generated when an alternating current flows through a conductor, such as an antenna. The reverse is true, too. When a radio wave hits an antenna, it causes a current to flow in the antenna

All electromagnetic waves, including radio waves, travel at the speed of light, or 300 million meters per sec-

ond.

T3B04

What is the velocity of a radio wave traveling through free space?

- A. **Speed of light**
- B. Speed of sound
- C. 0.86 times the speed of light
- D. 1.86 times the speed of sound

T3B11

What is the approximate velocity of a radio wave in free space?

- A. 150,000,000 meters per second
- B. **300,000,000 meters per second**
- C. 300,000,000 miles per hour
- D. 150,000,000 miles per hour

An important characteristic of a radio wave is its frequency, or the number of cycles per second. As mentioned earlier, the unit of frequency is the Hertz. We abbreviate Hertz as Hz, and one Hz is one cycle per second. All radio frequencies travel at the same velocity.

T3B12

Which of these frequencies travels at the highest velocity in free space?

- A. Microwaves
- B. UHF
- C. VHF
- D. **All radio frequencies travel at the same velocity**

A characteristic of a radio wave that is related to frequency is its wavelength. A wavelength is the distance that a radio wave travels during one cycle. Because radio waves travel at the speed of light, or 300,000,000 meters per second, the wavelength is 300,000,000 divided by the frequency. To make this easier to calculate, you can divide both the speed of light and the frequency by one million. That makes the equation:

$$\text{wavelength (m)} = 300/f \text{ (MHz)}$$

The converse of this equation is:

$$f \text{ (MHz)} = 300/\text{wavelength (m)}$$

As you can see from the equations, the lower the frequency, the longer the wavelength, and vice versa, the higher the frequency, the shorter the wavelength.

T3B06

What is the formula for converting frequency to approximate wavelength in meters?

- A. Wavelength in meters equals frequency in hertz multiplied by 300
- B. Wavelength in meters equals frequency in hertz divided by 300
- C. Wavelength in meters equals frequency in megahertz divided by 300
- D. **Wavelength in meters equals 300 divided by frequency in megahertz**

T3B05

What is the relationship between wavelength and frequency?

- A. Wavelength gets longer as frequency increases

- B. **Wavelength gets shorter as frequency increases**
- C. Wavelength is constant at all frequencies
- D. Wavelength and frequency increase as path length increases

In amateur radio, we sometimes use the frequency and sometimes the wavelength when talking about a radio signal. We use wavelength, for example, when we refer to the amateur radio bands. The 2 m amateur radio band, for example, spans 144 MHz to 148 MHz. A radio wave with a frequency of 148 MHz, would have a wavelength of 2.03 meters.

T3B07

In addition to frequency, which of the following is used to identify amateur radio bands?

- A. **The approximate wavelength in meters**
- B. Traditional letter/number designators
- C. Channel numbers
- D. All these choices are correct

For convenience, we split the entire range of radio frequencies into sub-ranges, including high frequency (HF), very high frequency (VHF), and ultra high frequency (UHF).

T3B10

What frequency range is referred to as HF?

- A. 300 to 3000 MHz
- B. 30 to 300 MHz
- C. **3 to 30 MHz**
- D. 300 to 3000 kHz

T3B08

What frequency range is referred to as VHF?

- A. 30 kHz to 300 kHz
- B. **30 MHz to 300 MHz**
- C. 300 kHz to 3000 kHz
- D. 300 MHz to 3000 MHz

T3B09

What frequency range is referred to as UHF?

- A. 30 to 300 kHz
- B. 30 to 300 MHz
- C. 300 to 3000 kHz
- D. **300 to 3000 MHz**

Radio wave propagation at VHF and UHF frequencies

As amateur radio operators, we should always try to use the right frequency and the right mode when communicating. To do this, we need to know how radio signals travel from one point to another and what effect frequency, our antennas and even our location have on signal propagation.

Communications at VHF and UHF frequencies are generally “line-of-sight” communications. This means they normally travel in a straight line from the transmitter to the receiver. For this reason, they are normally used for local communications.

Because VHF and UHF signals are line-of-sight, at some distance, the signals will be blocked by the curvature of the Earth. The maximum distance for line-of-sight communications is called the radio horizon. The radio horizon extends somewhat farther than the visual horizon.

T3C11

Why is the radio horizon for VHF and UHF signals more distant than the visual horizon?

- A. Radio signals move somewhat faster than the speed of light
- B. Radio waves are not blocked by dust particles
- C. The atmosphere refracts radio waves slightly**
- D. Radio waves are blocked by dust particles

T3C01

Why are simplex UHF signals rarely heard beyond their radio horizon?

- A. They are too weak to go very far
- B. FCC regulations prohibit them from going more than 50 miles
- C. UHF signals are usually not propagated by the ionosphere**
- D. UHF signals are absorbed by the ionospheric D region

Signals in the HF portion of the spectrum often bounce off the ionosphere. This gives them the ability to travel much further than the radio horizon. Unfortunately, this is not usually the case for UHF signals. They pass right through the ionosphere. We’ll talk more about the ionosphere later.

One problem often encountered when using VHF and UHF frequencies is multipath propagation. Multipath propagation occurs when your signals arrive at a receiving station via two or more paths. Since the signal paths may be different lengths, the signals may arrive out of phase and cancel one another or arrive in phase and reinforce one another. Moving an antenna only a few feet, say when you’re operating mobile, can cause the received signal strength to vary greatly.

T3A01

Why do VHF signal strengths sometimes vary greatly when the antenna is moved only a few feet?

- A. The signal path encounters different concentrations of water vapor
- B. VHF ionospheric propagation is very sensitive to path length
- C. Multipath propagation cancels or reinforces signals**
- D. The Doppler effect causes slight frequency shifts which result in changes in signal strength

This can be a real problem for mobile operation, as your transmitter and antenna location is constantly changing. This means that the signal strength at the receiving station constantly changes as well. This rapid

fluctuation in received signal strength is sometimes called *picket fencing*.

T3A06

What is the meaning of the term “picket fencing”?

- A. Alternating transmissions during a net operation
- B. Rapid flutter on mobile signals due to multipath propagation**
- C. A type of ground system used with vertical antennas
- D. Interference from cable TV in the form of carriers at fixed intervals across the band

Because it can cause signal strength to vary greatly, multipath propagation affects both voice and digital transmissions. Since reliable digital transmissions rely on the signals being relatively constant and strong, multipath propagation can cause errors to occur.

T3A10

What effect does multipath propagation have on data transmissions?

- A. Transmission rates must be increased by a factor equal to the number of separate paths observed
- B. Transmission rates must be decreased by a factor equal to the number of separate paths observed
- C. No significant changes will occur if the signals are transmitted using FM
- D. Error rates are likely to increase**

Knowing how VHF and UHF signals propagate can help you communicate even in adverse conditions. When trying to use a repeater, for example, you may find yourself in a place where a direct path to the repeater is not possible. If you find yourself in this situation, you could try using a directional antenna and bounce your signal off buildings or other obstructions.

T3A05

When using a directional antenna, how might your station be able to communicate with a distant repeater if buildings or obstructions are blocking the direct line of sight path?

- A. Change from vertical to horizontal polarization
- B. Try to find a path that reflects signals to the repeater**
- C. Try the long path
- D. Increase the antenna SWR

Another phenomenon you might use when a direct path to a repeater is not possible is “knife-edge” diffraction. Knife-edge diffraction occurs when a signal encounters a sharp obstacle — such as a building edge, mountain ridge, or rooftop — and bends around it. Rather than being completely blocked, the radio wave diffracts around the obstruction, allowing your signal to reach the receiving station.

T3C05

Which of the following effects may allow radio signals to travel beyond obstructions between the transmitting and receiving stations?

- A. Knife-edge diffraction**
- B. Faraday rotation
- C. Quantum tunneling
- D. Doppler shift

While vegetation is normally not a problem for amateur radio operation, it can absorb signals at UHF and microwave frequencies. Interestingly, the amount of absorption depends on the type of tree, leaf density, and moisture content of the tree's leaves.

T3A02

What is the effect of vegetation on UHF and microwave signals?

A. Causes knife-edge diffraction, distorting voice peaks

B. Absorbs signals, leading to poor reception of weak signals

C. Amplifies signals, improving reception of weak signals

D. Has no effect

Antenna polarization

Antenna polarization is important at VHF and UHF frequencies. How you mount an antenna directly affects its polarization. When the radiating element of an antenna is vertical, the electric field will be vertically polarized, and we say that the transmitted radio waves have a vertical polarization. When the radiating element of an antenna is horizontal, the electric field will be horizontally polarized, and we say that the radio waves have a horizontal polarization.

T9A03

How is the polarization of an antenna described?

- A. By the shape of the driven element
- B. By the orientation of the electric field**
- C. By the orientation of the magnetic field
- D. By the direction of radiation

T3B02

What property of a radio wave defines its polarization?

- A. The orientation of the electric field**
- B. The orientation of the magnetic field
- C. The ratio of the energy in the magnetic field to the energy in the electric field
- D. The ratio of the velocity to the wavelength

A repeater's antenna is most often vertically polarized. So, when using a handheld transceiver to access a repeater, make sure to hold the transceiver so that its antenna is straight up and down. This will ensure that the repeater receives as much of your signal as possible.

When a transmitting station's antenna is horizontally polarized, and the receiving station's antenna is vertically polarized—or vice versa—we say that the signal is cross polarized. Cross polarization reduces a signal's received signal strength.

T3A04

What is the effect of antenna cross-polarization over a line-of-sight VHF or UHF path?

- A. Modulation sidebands might become inverted
- B. Received signal strength is reduced**
- C. Signals have an echo effect
- D. Nothing significant will happen

Different operating activities use different antenna polarizations, though.

T3A03

What antenna polarization is normally used for long-distance CW and SSB contacts on the VHF and UHF bands?

- A. Right-hand circular
- B. Left-hand circular
- C. Horizontal**
- D. Vertical

The reason for this is that operators transmitting CW and SSB signals are often using what are called beam antennas, and it's much easier to mount and operate beam antennas horizontally than it is to mount them vertically.

Interesting propagation phenomena

Even though VHF communications are most often line-of-sight, there are some propagation modes that make it possible to communicate over long distances. For example, sometimes VHF signals will bounce off the E layer of the ionosphere. This phenomenon is called “sporadic E” propagation because it happens only sporadically.

T3C04

Which of the following types of propagation is most commonly associated with occasional strong signals on the 10-, 6-, and 2-meter bands from beyond the radio horizon?

- A. Backscatter
- B. Sporadic E**
- C. D region absorption
- D. Gray-line propagation

Other interesting propagation phenomena at VHF frequencies include auroral backscatter, meteor scatter, tropospheric scatter, and tropospheric ducting. Bouncing signals off the earth’s aurora is very interesting to do, but the signals usually become distorted and signal strength can vary greatly. This is because the aurora itself is constantly changing.

T3C03

What is one characteristic of VHF signals received via auroral backscatter?

- A. They are often received from 10,000 miles or more
- B. They are distorted, with a characteristic raspy sound**
- C. They occur only during winter nighttime hours
- D. They are generally strongest when your antenna is aimed west

Some hams also bounce signals off meteor showers. This propagation mode is called meteor scatter. Meteor scatter propagation is most pronounced on the 6-meter band.

T3C07

What band is best suited for communicating via meteor scatter?

- A. 33 centimeters
- B. 6 meters**
- C. 2 meters
- D. 70 centimeters

One question that I often get is whether or not the weather affects radio wave propagation. The short answer is no, but there are, of course, exceptions to this rule. One way that weather can affect radio propagation is when there is a temperature inversion in the atmosphere. A temperature inversion occurs when a layer of cooler air gets trapped below a layer of warmer air in the troposphere. The troposphere is the lowest region of the atmosphere, extending from the earth’s surface to a height of about 6–10 km.

When this happens, a *tropospheric duct* may form. VHF signals entering this duct may propagate through the duct for hundreds of miles.

T3C06

What type of propagation is responsible for allowing over-the-horizon VHF and UHF

communications to ranges of approximately 300 miles on a regular basis?

A. Tropospheric ducting

B. D region refraction

C. F2 region refraction

D. Faraday rotation

T3C08

What causes tropospheric ducting?

A. Discharges of lightning during electrical storms

B. Sunspots and solar flares

C. Updrafts from hurricanes and tornadoes

D. Temperature inversions in the atmosphere

Another exception to the rule occurs at microwave frequencies. Precipitation, including rain, snow, or ice can absorb microwave signals, thereby decreasing range.

T3A07

What weather condition might decrease range at microwave frequencies?

A. High winds

B. Low barometric pressure

C. Precipitation

D. Colder temperatures

At lower frequencies, however, precipitation has little or no effect on propagation.

T3A12

What effect does fog or rain have on 10-meter and 6-meter band signals?

A. Absorption

B. Little effect

C. Deflection

D. Increased range

HF propagation

For reliable long-distance communications, amateurs use the HF frequencies. The reason for this is that the ionosphere can reflect HF signals. This phenomenon allows amateur radio operators to contact other amateur radio stations around the world, and long-distance ionospheric propagation is far more common on HF frequencies than it is on VHF and higher frequencies.

The ionosphere is created by solar radiation, which creates a high concentration of ions and free electrons that reflect radio waves. It extends from about 50 to 600 miles above the earth's surface. There are three ionospheric layers—the D, E, and F layers—with the D layer being closest to the Earth, and the F layer being the layer farthest from the surface of the Earth.

T3A11

Which region of the atmosphere can reflect HF radio waves?

- A. The stratosphere
- B. The troposphere
- C. **The ionosphere**
- D. The electro sphere

T3C02

What is a characteristic of HF communication compared with communications on VHF and higher frequencies?

- A. HF antennas are generally smaller
- B. HF accommodates wider bandwidth signals
- C. **Long-distance ionospheric propagation is far more common on HF**
- D. There is less atmospheric interference (static) on HF

One interesting phenomenon that has an effect on HF propagation is the sunspot cycle. Generally, the number of sunspots increases and decreases over an 11-year cycle, and HF propagation, especially on the higher frequency HF bands, is best at times when there are many sunspots. The reason for this is that the more sunspots there are, the more solar radiation reaches earth. This radiation increases the amount of ionization in the ionosphere, which in turn, increases the ability of the ionosphere to reflect radio waves.

T3C10

Which of the following bands may provide long-distance communications via the ionosphere's F region during the peak of the sunspot cycle?

- A. **6 and 10 meters**
- B. 23 centimeters
- C. 70 centimeters and 1.25 meters
- D. All these choices are correct

Because of the way that the ionosphere changes throughout the day, propagation is best on the higher frequency bands (10m, 15m and 20m) during the day, while propagation is best on the lower frequency bands (160m, 80m, 40m) at night.

T3C09

What is generally the best time for long-distance 10-meter band propagation via the F region?

- A. **From dawn to shortly after sunset during periods of high sunspot activity**

- B. From shortly after sunset to dawn during periods of high sunspot activity
- C. From dawn to shortly after sunset during periods of low sunspot activity
- D. From shortly after sunset to dawn during periods of low sunspot activity

A common phenomenon of HF signal propagation is fading.

T3A08

What is a likely cause of irregular fading of signals propagated by the ionosphere?

- A. Frequency shift due to Faraday rotation
- B. Interference from thunderstorms
- C. Intermodulation distortion
- D. **Random combining of signals arriving via different paths**

This is similar to multipath distortion of VHF and UHF signals, but in this case, the signals are bouncing off the ionosphere, and because the ionosphere is constantly changing, signals fade in and out.

Antenna polarization is not as important when operating on the HF bands as it is when operating on the VHF/UHF bands. This is because signals “skip” off the ionosphere and become neither horizontally polarized, nor vertically polarized, but elliptically polarized.

T3A09

Which of the following results from the fact that signals propagated by the ionosphere are elliptically polarized?

- A. Digital modes are unusable
- B. **Either vertically or horizontally polarized antennas may be used for transmission or reception**
- C. FM voice is unusable
- D. Both the transmitting and receiving antennas must be of the same polarization

Antennas and feed lines

Antenna types

To transmit radio waves effectively, radio amateurs use a variety of antennas. To choose the right antenna, you have to consider a number of factors, including the frequency of the radio waves that you'll be transmitting, where you will be setting up the antenna, and in which direction the antenna radiates best.

The most common, and perhaps the simplest, antenna is the half-wave dipole antenna, shown in the figure below.

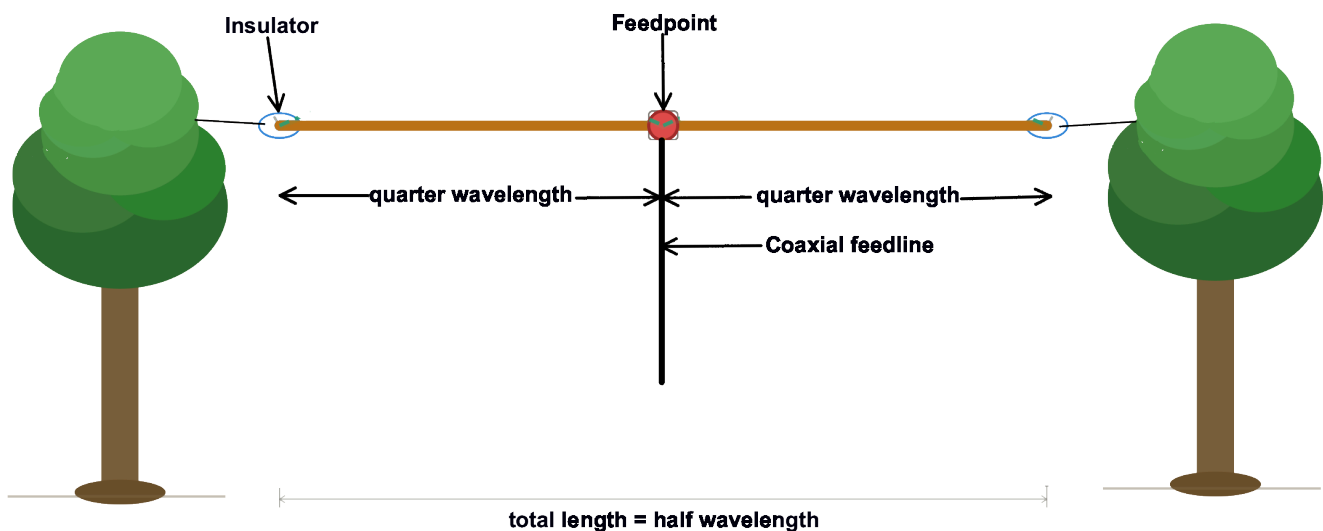

Figure 4-1. A half-wavelength dipole antenna is often supported by tall trees.

As the name suggests, it measures close to one half wavelength from one end of the antenna to the other. Because half-wave dipole antennas can be quite long—a 40m half-wave dipole antenna, for example, is about 66 feet long—they are normally mounted horizontally between two vertical supports. Radio amateurs often use tall trees to support dipole antennas.

When putting up a dipole antenna, you should consider the orientation of the antenna because it radiates the strongest signal broadside to the antenna than off the ends of the antenna.

T9A10

In which direction does a half-wave dipole antenna radiate the strongest signal?

- A. Equally in all directions
- B. Off the ends of the antenna
- C. In the direction of the feed line
- D. **Broadside to the antenna**

So, for example, if you live in Kansas, you might want to orient the antenna so that the wire runs north to

south. The antenna will then radiate best east and west, meaning that you'll be able to cover most of the U.S.

The length of a dipole antenna is actually about 5% shorter than the value that you would calculate using the formula $\text{wavelength (m)} = 300 / \text{frequency (MHz)}$. The reason for this is that there will be some stray capacitance between the wire and the ground and other objects near the antenna.

Once you have built a dipole antenna, chances are it won't be resonant on the frequency you want. To change the resonant frequency the antenna, you need to determine its resonant frequency and then make it longer or shorter. To decrease the resonant frequency of an antenna, you lengthen it, because the wavelength is longer. Conversely, to increase the resonant frequency, you shorten the antenna.

T9A05

Which of the following increases the resonant frequency of a dipole antenna?

- A. Lengthening it
- B. Inserting coils in series with radiating wires
- C. Shortening it
- D. Adding capacitive loading to the ends of the radiating wires

The final length will depend on the height at which you mount the antenna and any trees or buildings that are nearby.

Perhaps the second-most popular type of amateur radio antenna is the quarter-wave vertical antenna. The radiator of a vertical antenna is mounted perpendicular to the Earth. This makes it vertically-polarized, because the electric field will have the same orientation as the antenna's radiator.

Like the half-wave dipole antenna, the length of a quarter-wave vertical antenna will be about 5% shorter than the calculated quarter wavelength. That means a resonant quarter-wavelength vertical for use on 2 meters is about 19 inches.

T9A08

Why is a 19-inch-long vertical antenna often used on 2 meters?

- A. It has high gain
- B. It is a resonant half-wave
- C. It is a resonant quarter-wave
- D. It has low RF radiation exposure

Here's how you calculate that:

- One quarter of a wavelength on 2 meters is 0.5 m.
- $0.5 \text{ m} \times 39.4 \text{ in/m} = 19.7 \text{ in.}$
- $19.7 \text{ in} \times 0.95 \approx 19 \text{ in.}$

Because full-size, half-wave or quarter-wave HF antennas can be very long, many amateurs use a technique called "loading" to shorten them. You can use either inductors or capacitors to load an antenna, but the most common way is to use an inductor. In either case, loading an antenna makes it seem electrically longer

to a signal at the antenna feed point.

T9A02

Which of the following describes a type of antenna loading?

- A. **Electrically lengthening by inserting inductors in radiating elements**
- B. Inserting a resistor in the radiating portion of the antenna to make it resonant
- C. Installing a spring in the base of a mobile vertical antenna to make it more flexible
- D. Strengthening the radiating elements of a beam antenna to better resist wind damage

While this technique does allow you to shorten an antenna, the shortened antenna will not be as efficient as a full-size antenna.

Many amateurs use directional or *beam antennas*. Beam antennas concentrate the power that is applied to them in one direction, thereby increasing the signal strength in that direction, when compared to a reference antenna, such as a dipole antenna. We call this increase in signal strength *antenna gain*. There are many different types of beam antennas, including the Yagi, the quad, and the dish antenna.

T9A01

What is a beam antenna?

- A. An antenna built from square aluminum beams
- B. An omnidirectional antenna invented by Clarence Beam
- C. **An antenna that concentrates signals in one direction**
- D. An antenna that focuses the signal into two intense rays

T9A11

What is antenna gain?

- A. The additional power that is added to the transmitter power
- B. The additional power that is required in the antenna when transmitting on a higher frequency
- C. **The increase in signal strength in a specified direction compared to a reference antenna**
- D. The increase in impedance on receive or transmit compared to a reference antenna

T9A06

Which of the following types of antennas offers the greatest gain?

- A. 5/8 wave vertical
- B. Isotropic
- C. J pole
- D. **Yagi**

Most handheld VHF and UHF transceivers come with short, flexible antennas, often jokingly referred to as “rubber ducks.” These antennas use inductive loading to make them shorter than a full-sized antenna. Loading them like this makes them less efficient than a full-sized quarter-wavelength vertical antenna.

T9A04

What is a disadvantage of a handheld radio transceiver’s short, flexible antenna compared to a full-sized quarter-wave antenna?

- A. **It has low efficiency**

- B. It transmits only circularly polarized signals
- C. It is more susceptible to receiver desensitization
- D. It only works on analog signals, not digital ones

This disadvantage is compounded if you try to use a handheld VHF transceiver inside a vehicle. The shielding effect of the vehicle's metal frame will prevent some of your signal from getting outside the vehicle and block some of the signal from a repeater or other station from reaching the antenna inside the vehicle.

T9A07

What is a disadvantage of using a handheld VHF transceiver with a flexible antenna inside a vehicle?

- A. **Signal strength is reduced due to the shielding effect of the vehicle**
- B. The bandwidth of the antenna will decrease, increasing SWR
- C. The SWR might decrease, decreasing the signal strength
- D. All these choices are correct

A better option is to use an externally-mounted antenna. A popular choice for an externally-mounted mobile antenna is the 5/8-wavelength vertical antenna. One reason that it is a popular choice, is that it has more gain than a 1/4-wavelength antenna.

T9A09

What is an advantage of a 5/8 wavelength whip antenna for VHF or UHF mobile service compared to a 1/4-wave antenna?

- A. **It has more gain**
- B. It radiates at a higher angle
- C. It has lower SWR
- D. It has lower impedance

Feed lines and connectors

Feed lines connect radios to antennas. There are many different types of feed lines, including coaxial cable, ladder line, twin lead, and open-wire feed line, but coaxial cable is the most common type.

T9B03

Why is coaxial cable the most common feed line for amateur radio antenna systems?

- A. **It is easy to use and requires few special installation considerations**
- B. It has less loss than any other type of feed line
- C. It can handle more power than any other type of feed line
- D. It is less expensive than any other type of feed line

Perhaps the most important consideration when choosing a feed line is the impedance of the feed line. In general, you should match the impedance of the feed line to the output impedance of the transmitter and the input impedance of the antenna.

T5C12

What is impedance?

- A. **The opposition to AC current flow**
- B. The inverse of resistance
- C. The inverse of reactance
- D. The power handling capability of a component

T5C05

What is the unit of impedance?

- A. Volt
- B. Ampere
- C. Coulomb
- D. **Ohm**

Most amateur radio transmitters have an output impedance of 50 ohms, and most antennas have an input impedance close to 50 ohms. Because this is the case, most coaxial cable used in amateur radio stations has an impedance of 50 ohms.

T9B02

What is the most common impedance of coaxial cables used in amateur radio?

- A. 8 ohms
- B. **50 ohms**
- C. 600 ohms
- D. 12 ohms

RG-58 and RG-213 are two types of coaxial cable often used in amateur radio stations. Both have an impedance of 50 ohms.

Despite being the most popular type of feedline for amateur radio stations, coaxial cable does have some disadvantages. One of them is that it may be lossy at high frequencies. Some coax cable types have more loss than others.

T9B05

What happens as the frequency of a signal in coaxial cable is increased?

- A. The characteristic impedance decreases
- B. The loss decreases
- C. The characteristic impedance increases
- D. **The loss increases**

T9B10

What is the electrical difference between RG-58 and RG-213 coaxial cable?

- A. There is no significant difference between the two types
- B. RG-58 cable has two shields
- C. **RG-213 cable has less loss at a given frequency**
- D. RG-58 cable can handle higher power levels

What this means in practice is that using RG-58 coax as the feed line for an 80 m dipole might be just fine, but you don't want to use 50 feet of RG-58 to connect your 440 MHz FM transceiver to an antenna on your roof or on a tower.

Even RG-213 coaxial cable is not really the best choice for use at VHF and UHF frequencies. Most repeaters, for example, use air-insulated hard line coaxial cable for the feed line.

T9B11

Which of the following types of feed line has the lowest loss?

- A. 50-ohm flexible coax
- B. Multi-conductor unbalanced cable
- C. **Air-insulated hardline**
- D. 75-ohm flexible coax

Many other factors, including water intrusion, high SWR, and multiple connectors in line can cause losses in a coaxial feed line.

T9B08

Which of the following is a source of loss in coaxial feed line?

- A. Water intrusion into coaxial connectors
- B. High SWR
- C. Multiple connectors in the line
- D. **All these choices are correct**

The type of dielectric—which is the type of material that separates the braid from the shield—also affects coaxial cable loss. Coaxial cables with a foam dielectric have less loss per foot than cables with a solid dielectric.

T7C11

What is an advantage of foam-dielectric versus solid-dielectric coaxial cable?

- A. It is more resistant to moisture contamination
- B. It has higher voltage breakdown
- C. **It has less loss per foot**
- D. It has a better impedance match to 50 ohms

Moisture contamination not only causes higher feed line losses. If not addressed, it can also cause coaxial cables to fail.

T7C09

Which of the following causes failure of coaxial cables?

- A. **Moisture contamination**
- B. Solder flux contamination
- C. Rapid fluctuation in transmitter output power
- D. Operation at 100% duty cycle for an extended period

To prevent moisture contamination, you should carefully tape RF connectors when used outdoors to prevent moisture from getting into the feed line. This applies to PL-259, BNC, and type N connectors.

T9B01

Which of the following connectors should be carefully taped for weather protection when used outdoors?

- A. PL259
- B. BNC
- C. Type N
- D. **All these choices are correct**

One way that moisture gets into a cable is via cracks in the cable's outer jacket caused by ultraviolet light.

T7C10

Why should the outer jacket of coaxial cable be resistant to ultraviolet light?

- A. Ultraviolet light can increase the resistance of the conductors
- B. Ultraviolet light can increase losses in the cable's jacket
- C. Ultraviolet and RF signals can mix, causing interference
- D. **Ultraviolet light can damage the jacket and allow water to enter the cable**

PL-259 connectors are the most common type of connectors used on coaxial cables in amateur radio stations.

T9B07

Which of the following is true of PL-259 type coax connectors?

- A. They are preferred for microwave operation
- B. They are watertight
- C. **They are commonly used at HF and VHF frequencies**
- D. They are a bayonet-type connector

One problem with PL-259 connectors is that they are not the most suitable connector when operating at higher frequencies. Even though PL-259 connectors are called UHF connectors, Type N connectors are a much better choice for UHF frequencies.

T9B06

Which of the following connector types is most suitable as an RF connector for frequencies above 400 MHz?

- A. PL-259

- B. Type N**
- C. RS-213
- D. DB-25

Standing wave ratio and antenna measurements

Standing wave ratio, or SWR, is a term you'll often hear when talking about antennas and feed lines. It is a measure of how well a load, such as an antenna, is matched to a transmission line. When we say that an antenna is matched to a transmission line, we mean that the impedance of the transmission line is equal to the impedance of the antenna. If you measure the SWR of a perfectly-matched antenna system, the SWR meter will read 1:1. The higher the SWR reading, the greater the mismatch between the antenna and the transmission line.

T7C04

What reading on an SWR meter indicates a perfect impedance match between the antenna and the feed line?

- A. 50:50
- B. Zero
- C. 1:1**
- D. Full Scale

T7C06

What does an SWR reading of 4:1 indicate?

- A. Loss of -4 dB
- B. Good impedance match
- C. Gain of +4 dB
- D. Impedance mismatch**

When the feed line impedance matches the antenna input impedance, the SWR will be low. Low SWR on a coaxial cable feed line is a good thing because when the feed line impedance matches the antenna input impedance, signal losses are low, meaning that the antenna will radiate more power.

The bigger the mismatch is between the feed line and the load, the higher the SWR will be. The higher the SWR, the more power is lost in the feed line. Power converted into heat is not radiated by the antenna, meaning your radiated signal will be weaker.

T7C07

What happens to power lost in a feed line?

- A. It increases the SWR
- B. It is radiated as harmonics
- C. It is converted into heat**
- D. It distorts the signal

Improperly installed coaxial cable connectors or loose connections can cause high SWR or erratic changes in SWR in an antenna system. When installing a connector on a feed line, make sure that your coaxial connectors are crimped or soldered properly, and when connecting a feed line to an antenna, make sure that it makes a solid connection to the antenna.

T9B09

What can cause erratic changes in SWR?

- A. Local thunderstorm
- B. Loose connection in the antenna or feed line**

- C. Over-modulation
- D. Overload from a strong local station

Most amateur radio transceivers today will reduce output power if the antenna system SWR is high. The reason for this is to protect the radio from being damaged by reflected power.

T7C05

Why do most solid-state transmitters reduce output power as SWR increases beyond a certain level?

- A. **To protect the RF output amplifier transistors**
- B. To comply with FCC rules on spectral purity
- C. Because power supplies cannot supply enough current at high SWR
- D. To lower the SWR on the transmission line

When choosing an SWR meter, be sure to note the frequency range over which the meter will operate and the maximum power level at which you can use the meter. Using a meter outside of the specified range can result in erroneous readings, and using a meter above the maximum power level can damage the meter.

T4A02

Which of the following should be considered when selecting an accessory SWR meter?

- A. **The frequency and power level at which the measurements will be made**
- B. The distance that the meter will be located from the antenna
- C. The maximum SWR anticipated on the transmission line
- D. The ability of the meter to compensate for a poor transmission line match to the antenna

An SWR meter is not the only way to measure SWR. You can also measure SWR with a directional wattmeter.

T7C08

Which instrument can be used to determine SWR?

- A. Voltmeter
- B. Ohmmeter
- C. Iambic pentameter
- D. **Directional wattmeter**

When using a directional wattmeter, you first measure the forward power, then the reflected power, and using those two values, calculate the SWR. Since the wattmeter measures power, you should install it in the feedline, between the transmitter and antenna.

T4A05

Where should an RF power meter be installed?

- A. **In the feed line, between the transmitter and antenna**
- B. At the power supply output
- C. In parallel with the push-to-talk line and the antenna
- D. In the power supply cable, as close as possible to the radio

Another test instrument that you can use to measure the SWR of an antenna system is the antenna analyz-

er. The SWR of an antenna system will be 1:1 at the resonant frequency.

T7C02

Which of the following is used to determine if an antenna is resonant at the desired operating frequency?

- A. A VTVM
- B. An antenna analyzer**
- C. A Q meter
- D. A frequency counter

Some antenna analyzers will also let you measure capacitive reactance and inductive reactance, and also be used as an RF signal generator. These capabilities may be useful in applications other than antenna analysis.

If an antenna's impedance is not 50 ohms, the impedance at the transmitter end of a feed line will not be 50 ohms. Don't worry, though. You can use a device called an antenna tuner or antenna coupler to transform the impedance from whatever it happens to be to 50 ohms. We call this process impedance matching.

T9B04

What is the major function of an antenna tuner (antenna coupler)?

- A. It matches the antenna system impedance to the transceiver's output impedance**
- B. It helps a receiver automatically tune in weak stations
- C. It allows an antenna to be used on both transmit and receive
- D. It automatically selects the proper antenna for the frequency band being used

In addition to instruments that make antenna measurements, it's helpful to have an instrument that can simulate an antenna. That's the purpose of a dummy load. Basically, a dummy load is just a big 50-ohm resistor that provides a known impedance to the transmitter and converts the transmitter output power into heat so that it does not get radiated. If a transmitter operates normally when a dummy load is connected to it, you can be reasonably sure that your transmitter is working properly.

T7C01

What is the primary purpose of a dummy load?

- A. To prevent transmitting signals over the air when making tests**
- B. To prevent over-modulation of a transmitter
- C. To improve the efficiency of an antenna
- D. To improve the signal-to-noise ratio of a receiver

T7C03

What does a typical dummy load consist of?

- A. A low-voltage power supply and an AC relay
- B. A 50-ohm non-inductive resistor mounted on a heat sink**
- C. A low-voltage power supply and a DC relay
- D. A 50-ohm inductive reactance mounted in a shielded enclosure

Amateur radio signals

Modulation modes and signal bandwidth

To transmit an audio signal, such as plain speech, or a data signal, we have to combine speech or an audio frequency signal with an RF signal. This process, called modulation, causes the amplitude, frequency, phase, or intensity of the RF signal to vary in accordance with the audio or data input.

T7A08

Which of the following describes combining speech with an RF carrier signal?

- A. Impedance matching
- B. Oscillation
- C. Modulation**
- D. Low-pass filtering

There are several different types of modulation, but when you get your Technician license, chances are that frequency modulation (FM) or phase modulation (PM), is the type of modulation that you'll use first. When you frequency modulate or phase modulate a radio signal, the audio actually changes the frequency of the signal a little in proportion to the volume of the audio signal. An FM receiver detects this frequency change and recreates the audio.

T8A04

Which type of modulation is commonly used for VHF and UHF voice repeaters?

- A. AM
- B. SSB
- C. PSK
- D. FM or PM**

Packet radio is a way to send digital information over the air. On VHF, this is usually done using an FM or PM signal. The digital information is sent by changing the frequency of the audio. For example, a VHF packet radio transmission with a data rate of 1200 baud normally uses a frequency of 2200 Hz for the space and 1200 Hz for the mark.

T8A06

Which sideband is normally used for 10-meter HF, VHF, and UHF single-sideband communications?

- A. Upper sideband**
- B. Lower sideband
- C. Suppressed sideband
- D. Inverted sideband

Amplitude modulation, or AM, is another type of modulation. To amplitude modulate a signal, you vary the amplitude of the signal in proportion to the audio level. Single-sideband, or SSB, is a form of amplitude modulation. SSB is a better choice than FM for long-distance (weak signal) contacts on the VHF and UHF bands because it is more energy-efficient than FM, and this is important when trying to send signals long distances.

T8A01

Which of the following is a form of amplitude modulation?

- A. Spread spectrum
- B. Packet radio
- C. Single sideband**
- D. Phase shift keying (PSK)

T8A03

Which type of voice mode is often used for long-distance (weak signal) contacts on the VHF and UHF bands?

- A. FM
- B. DRM
- C. SSB**
- D. PM

A single-sideband signal may be upper-sideband (USB) or lower-sideband (LSB). On frequencies above 14 MHz, amateurs normally use upper sideband.

T8A06

Which sideband is normally used for 10 meter HF, VHF, and UHF single-sideband communications?

- A. Upper sideband**
- B. Lower sideband
- C. Suppressed sideband
- D. Inverted sideband

The audio of an FM signal sounds better than an AM signal, but it occupies a wider bandwidth than an AM or single sideband signal. This means that you can have fewer FM signals in a given frequency range than SSB signals. A SSB signal is typically 3 kHz wide, while a VHF FM repeater voice signal is 10 – 15 kHz. wide.

T8A07

What is one characteristic of single sideband (SSB) compared to FM?

- A. SSB signals are easier to tune in correctly
- B. SSB signals are less susceptible to interference
- C. SSB signals have narrower bandwidth**
- D. SSB signals are less susceptible to high SWR

T8A08

What is the approximate bandwidth of a typical single sideband (SSB) voice signal?

- A. 1 kHz
- B. 3 kHz**
- C. 6 kHz
- D. 15 kHz

T8A09

What is the approximate bandwidth of an FM voice signal on VHF repeaters?

- A. Less than 500 Hz
- B. About 150 kHz
- C. Between 10 and 15 kHz**
- D. Between 50 and 125 kHz

Another disadvantage of FM when compared to SSB signals is that you can only receive one signal at a time. When two signals are present at the input of an FM receiver, the receiver will suppress the weaker signal and only demodulate the stronger signal. This is known as the capture effect.

T8A12

Which of the following is a disadvantage of FM compared with single sideband?

- A. Voice quality is poorer
- B. Only one signal can be received at a time**
- C. FM signals are harder to tune
- D. FM signals are more susceptible to high SWR

Some modes have very wide bandwidths, such as AM fast-scan TV. Analog fast-scan color TV signals are sometimes referred to as NTSC signals because the standard for this type of signal was established by the National Television System Committee, or NTSC.

T8A10

What is the approximate bandwidth of AM fast-scan TV transmissions?

- A. More than 10 MHz
- B. About 6 MHz**
- C. About 3 MHz
- D. About 1 MHz

T8D04

What is meant by the term "NTSC?"

- A. A digital transmission standard for encrypting data
- B. A special mode for satellite uplink
- C. An analog fast-scan color TV signal**
- D. A frame compression scheme for TV signals

Morse Code, or CW, signals have a narrower bandwidth than either AM or FM. The bandwidth of a CW signal is approximately 150 Hz. Technicians have CW privileges on the 80m, 40m, 15m, and 10m bands, as well as all the VHF, UHF, and microwave bands.

T8D09

What is CW?

- A. A type of electromagnetic propagation
- B. A digital mode used primarily on 2-meter FM
- C. Error correction for digital transmission using code words
- D. Another name for a Morse code transmission**

T8A05

Which of the following signal types has the narrowest bandwidth?

- A. FM voice
- B. SSB voice
- C. CW**
- D. Slow-scan TV

T8A11

What is the approximate bandwidth required to transmit a CW signal?

- A. 2.4 kHz
- B. 150 Hz**
- C. 1000 Hz
- D. 15 kHz

To send Morse Code you can use a *straight key* or a *paddle*. A straight key has one set of contacts, and you make the dits and dahs manually by holding it down for different lengths of time. A paddle, on the other hand, has two sets of contacts which are connected to an *electronic keyer*. When one set of contacts is closed, the electronic keyer sends dits. When the other set is closed, the electronic keyer sends dahs.

T4A12

What is an electronic keyer?

- A. A device for switching antennas from transmit to receive
- B. A device for voice activated switching from receive to transmit
- C. A device that assists in manual sending of Morse code**
- D. An interlock to prevent unauthorized use of a radio

Digital modes: packet, PSK31

When hams talk about “digital modes,” we are talking about modes that send digital data rather than voice or other types of analog signals, such as television. Usually, we connect our transceivers to a computer to modulate and demodulate the digital signals, but some transceivers can do this internally.

T8D01

Which of the following is a digital communications mode?

- A. Packet radio
- B. IEEE 802.11
- C. FT8
- D. **All these choices are correct**

Packet radio was one of the first digital modes. It is called packet radio because the data to be sent from station to station are separated into a number of packets which are then sent separately by the transmitting station and received and re-assembled by the receiving station.

T8D08

Which of the following is included in packet radio transmissions?

- A. A checksum that permits error detection
- B. A header that contains the call sign of the station to which the information is being sent
- C. Automatic repeat request in case of error
- D. **All these choices are correct**

Some amateur radio digital communications systems use protocols which ensure error-free communications. One such system is called an automatic repeat request, or ARQ, transmission system.

T8D11

What is the role of ARQ in a transmission system?

- A. A special transmission format limited to video signals
- B. A system used to encrypt command signals to an amateur radio satellite
- C. **An error correction method in which the receiving station detects errors and sends a request for retransmission**
- D. A method of compressing data using autonomous reiterative Q codes prior to final encoding

Automatic Packet Reporting System, or APRS, is one service that uses packet radio. The major application of APRS is to send location reports while operating a mobile amateur radio station. It can do this because APRS stations generally include a GPS receiver. In addition to sending GPS position data, radio amateur also use APRS to send text messages, and weather data.

T8D05

Which of the following is an application of APRS?

- A. **Providing real-time tactical digital communications in conjunction with a map showing the locations of stations**
- B. Automatically showing the number of packets transmitted via PACTOR during a specific time interval
- C. Providing voice over internet connection between repeaters

D. Providing information on the number of stations signed into a repeater

T8D03

What kind of data can be transmitted by APRS?

A. GPS position data

B. Text messages

C. Weather data

D. All these choices are correct

Phase shift keying (PSK) is a digital modulation scheme widely used in amateur radio in which data is encoded by shifting the phase of a carrier signal rather than varying its amplitude or frequency. The most popular variant among amateur operators is PSK31. The "31" in PSK31 comes from the fact that data is transmitted and received at about 31 baud and that the bandwidth of a PSK31 signal is only about 31 Hz. Fortunately, that is about how fast most people can type.

T8D06

What does the abbreviation "PSK" mean?

A. Pulse Shift Keying

B. Phase Shift Keying

C. Packet Sampled Keying

D. Power Sampled Keying

Digital Mobile Radio, or DMR, is an FM digital communications system that's become quite popular in amateur radio. It allows amateur radio operators to use the spectrum more efficiently by time-multiplexing two signals in a single 12.5 kHz repeater channel. It also allows amateur radio operators to connect with one another over the internet.

T8D07

Which of the following describes DMR?

A. A technique for time-multiplexing two digital voice signals on a single 12.5 kHz repeater channel

B. An automatic position tracking mode for FM mobiles communicating through repeaters

C. An automatic computer logging technique for hands-off logging when communicating while operating a vehicle

D. A digital technique for transmitting on two repeater inputs simultaneously for automatic error correction

WSJT-X software is software that provides weak-signal digital communication modes on amateur radio frequencies. The WSJT-X software suite is used for Earth-Moon-Earth (EME) contacts, weak signal propagation beacons, and meteor scatter. To communicate with one of the digital modes that WSJT software provides, you need a single sideband transceiver and a personal computer with a sound card.

T8D10

Which of the following operating activities is supported by digital mode software in the WSJT-X software suite?

A. Earth-Moon-Earth

- B. Weak signal propagation beacons
- C. Meteor scatter
- D. **All these choices are correct**

FT8 is one of the modes supported by WSJT.

T8D02

What is FT8?

- A. A wideband FM voice mode
- B. **A digital mode capable of low signal-to-noise operation**
- C. An eight channel multiplex mode for FM repeaters
- D. A digital slow-scan TV mode with forward error correction and automatic color compensation

Mesh networking is another amateur radio activity that's becoming popular. Mesh networks use WiFi frequencies that just happen to be part of the 2.4 GHz, 5.8 GHz, and 10 GHz amateur radio bands. Mesh networks allow amateur radio stations to establish digital communications links for supporting high-speed emergency communications and internet connectivity. Broadband-Hamnet and Amateur Radio Emergency Data Network (AREDN) are two projects that use mesh networking to provide digital communications.

T8D12

Which of the following best describes an amateur radio mesh network?

- A. **An amateur-radio data network using commercial Wi-Fi equipment with modified firmware**
- B. A wide-bandwidth digital voice mode employing DMR protocols
- C. An amateur-radio satellite communications network using modified commercial satellite TV hardware
- D. An internet linking protocol allowing communication through repeaters around the world

Amateur radio station safety

Electrical safety

BE SAFE!

When operating or working on amateur radio equipment, it's possible to come into contact with dangerous voltages and currents. People have died working on high-voltage circuits. Because it would be a shame to lose a single person, it's important to know how to be safe when working with electricity.

30 volts is the commonly accepted value for the lowest voltage that can cause a dangerous electric shock, and only 100 mA flowing through the body can cause death. These are not very large values.

T0A02

What health hazard is posed by electrical current flowing through the body?

- A. It may cause injury by heating tissue
- B. It may disrupt the electrical functions of cells
- C. It may cause involuntary muscle contractions
- D. **All these choices are correct**

Start by ensuring that your amateur radio station has three-wire electrical outlets that are properly wired and grounded. When properly wired, three-wire electrical outlets and plugs are safer than two-wire outlets and plugs, and you should use three-wire plugs for all of your amateur radio equipment. In the United States, the three wires are hot, neutral, and safety ground, These are color-coded black, white, and green, respectively. In addition to ensuring that all AC outlets are properly wired, install mechanical interlocks in high-voltage circuits that disconnect power when equipment enclosures that contain those circuits are opened.

T0A03

In the United States, what circuit does black wire insulation indicate in a three-wire 120 V cable?

- A. Neutral
- B. **Hot**
- C. Equipment ground
- D. Negative

T0A06

What is a good way to guard against electrical shock at your station?

- A. Use three-wire cords and plugs for all AC powered equipment
- B. Connect all AC powered station equipment to a common safety ground
- C. Ensure all capacitors used for high-voltage DC are fully discharged before working inside equipment
- D. **All these choices are correct**

Installing fuses in an electrical circuit is the main way to protect a circuit from excessive current flow, or overload. Fuses are designed to “blow” or remove power from equipment if the current flowing through them exceeds a specified value. Fuses should always be in series with the hot conductor only.

T0A04

What is the purpose of a fuse in an electrical circuit?

- A. To prevent power supply ripple from damaging a component
- B. To remove power in case of an overload**
- C. To limit current and prevent shocks
- D. All these choices are correct

T0A08

Where should a fuse or circuit breaker be installed in a 120V AC power circuit?

- A. In series with the hot conductor only**
- B. In series with the hot and neutral conductors
- C. In parallel with the hot conductor only
- D. In parallel with the hot and neutral conductors

When replacing a fuse, always replace the blown fuse with a fuse of the same type and value. Using a fuse with a larger current rating may allow excessive current to flow in the circuit and cause it to catch fire.

T0A05

Why should a 5-ampere fuse never be replaced with a 20-ampere fuse?

- A. The larger fuse would be likely to blow because it is rated for higher current
- B. The power supply ripple would greatly increase
- C. Excessive current could cause a fire**
- D. Voltage drop in the higher current fuse could result in excessively low voltage to the device

Whenever you're working on equipment, be sure to disconnect it from the power lines, and even then be careful when working near a power supply's capacitors. Some power supplies have large capacitors in their output circuits that can store a lot of charge, and if you come into contact with them before they are discharged, you may receive an electrical shock. I always measure a power supply's output voltage before working on it or connecting or disconnecting equipment to the supply.

T0A11

What hazard exists in a power supply immediately after turning it off?

- A. Circulating currents in the dc filter
- B. Leakage flux in the power transformer
- C. Voltage transients from kickback diodes
- D. Charge stored in filter capacitors**

You also need to take precautions when using batteries to power your amateur radio station. Conventional 12-volt storage batteries present several safety hazards.

T0A01

Which of the following is a safety hazard of a 12-volt storage battery that lacks internal protection circuitry?

- A. Touching both terminals with the hands can cause electrical shock
- B. Shorting the terminals can cause burns, fire, or an explosion**
- C. RF emissions from a nearby transmitter can cause the electrolyte to emit poison gas

D. All these choices are correct

T0A10

What hazard exists when rapidly charging or discharging an unprotected battery?

A. Overheating or out-gassing

B. Excess output ripple

C. Electric shock

D. Overvoltage

Antenna and tower safety

Antenna safety is also of primary concern. There are two aspects of antenna safety—being safe when installing an antenna and safely operating an antenna. When installing an antenna, make sure you note where the power lines are and position the antenna, so that if it falls, no part of it comes closer than 10 feet to the power wires.

T0B04

Which of the following is an important safety precaution to observe when putting up an antenna tower?

- A. Wear a ground strap connected to your wrist at all times
- B. Insulate the base of the tower to avoid lightning strikes
- C. Look for and stay clear of any overhead electrical wires**
- D. All these choices are correct

T0B06

What is the minimum safe distance from a power line to allow when installing an antenna?

- A. Add the height of the antenna to the height of the power line and multiply by a factor of 1.5
- B. The height of the power line above ground
- C. 1/2 wavelength at the operating frequency
- D. Enough so that if the antenna falls, no part of it can come within 10 feet of the power wires**

And, you should NEVER attach an antenna to a utility pole because it could contact high-voltage power lines.

T0B09

Why should you avoid attaching an antenna to a utility pole?

- A. The antenna will not work properly because of induced voltages
- B. The antenna may unbalance the power transformer, causing power fluctuations
- C. The antenna could contact high-voltage power lines**
- D. All these choices are correct

You also should position the antenna so that no one can touch it while you are transmitting.

T0C07

What hazard is created by touching an antenna during a transmission?

- A. Electrocution
- B. RF burn to skin**
- C. Exposure to ionizing radiation
- D. All these choices are correct

There are a number of things you should keep in mind when putting up a tower and installing antennas on them.

T0B02

What is required when climbing an antenna tower?

- A. Have sufficient training on safe tower climbing techniques

- B. Use appropriate tie-off to the tower at all times
- C. Always wear an approved climbing harness
- D. **All these choices are correct**

T0B03

Under what circumstances is it safe to climb a tower without a helper or observer?

- A. When no electrical work is being performed
- B. When no mechanical work is being performed
- C. When the work being done is not more than 20 feet above the ground
- D. **Never**

T0B07

Which of the following is an important safety rule to remember when using a crank-up tower?

- A. This type of tower must never be painted
- B. This type of tower must never be grounded
- C. **This type of tower must not be climbed unless it is retracted, or mechanical safety locking devices have been installed**
- D. All these choices are correct

T0B05

What is the purpose of a safety wire through a turnbuckle used to tension guy lines?

- A. Secure the guy line if the turnbuckle breaks
- B. **Prevent loosening of the turnbuckle from vibration**
- C. Provide a ground path for lightning strikes
- D. Provide an ability to measure for proper tensioning

Grounding is very important when installing a tower. The tower is, after all, basically a big lightning rod. Proper grounding will help shunt a lightning strike to earth before it can get into your amateur radio station.

T0B11

Which of the following establishes grounding requirements for an amateur radio tower or antenna?

- A. FCC Part 97 rules
- B. **Local electrical codes**
- C. FAA tower lighting regulations
- D. UL recommended practices

T0B08

Which is a proper grounding method for a tower?

- A. A single four-foot ground rod, driven into the ground no more than 12 inches from the base
- B. A ferrite-core RF choke connected between the tower and ground
- C. A connection between the tower base and a cold-water pipe
- D. **Separate eight-foot ground rods for each tower leg, bonded to the tower and each other**

T0B01

Which of the following is good practice when installing ground wires on a tower for lightning protection?

- A. Put a drip loop in the ground connection to prevent water damage to the ground system
- B. Make sure all ground wire bends are right angles
- C. Ensure that connections are short and direct**
- D. All these choices are correct

T0B10

Which of the following is true when installing grounding conductors used for lightning protection?

- A. Use only non-insulated wire
- B. Wires must be carefully routed with precise right-angle bends
- C. Sharp bends must be avoided**
- D. Common grounds must be avoided

T0A09

What should be done to all external ground rods or earth connections?

- A. Waterproof them with silicone caulk or electrical tape
- B. Keep them as far apart as possible
- C. Bond them together with heavy wire or conductive strap**
- D. Tune them for resonance on the lowest frequency of operation

Lightning can also be conducted down a feed line and into your station. To prevent this, several manufacturers make devices called lightning arrestors that are designed to conduct this current to ground before it gets into the station. Mount lightning arrestors on a grounded panel near where feed lines enter a building.

T0A07

Where should a lightning arrester be installed in a coaxial feed line?

- A. At the output connector of a transceiver
- B. At the antenna feed point
- C. At the AC power service panel
- D. On a grounded panel near where feed lines enter the building**

RF hazards and radiation exposure

Even though radio waves are non-ionizing radiation, over-exposure to RF energy can be a safety hazard.

T0C01

What type of radiation are radio signals?

- A. Gamma radiation
- B. Ionizing radiation
- C. Alpha radiation
- D. **Non-ionizing radiation**

T0C12

How does RF radiation differ from ionizing radiation (radioactivity)?

- A. **RF radiation does not have sufficient energy to cause chemical changes in cells and damage DNA**
- B. RF radiation can only be detected with an RF dosimeter
- C. RF radiation is limited in range to a few feet
- D. RF radiation is perfectly safe

To ensure that your amateur radio station is operating safely, the FCC has set exposure limits. As an amateur radio station licensee, you are responsible for ensuring that no person is exposed to RF energy above these limits. There are three ways to determine whether your station complies with FCC RF exposure regulations:

- By calculation based on FCC OET Bulletin 65
- By calculation based on computer modeling
- By measurement of field strength using calibrated equipment

T0C13

Who is responsible for ensuring that no person is exposed to RF energy above the FCC exposure limits?

- A. The FCC
- B. **The station licensee**
- C. Anyone who is near an antenna
- D. The local zoning board

T0C06

Which of the following is an acceptable method to determine whether your station complies with FCC RF exposure regulations?

- A. By calculation based on FCC OET Bulletin 65
- B. By calculation based on computer modeling
- C. By measurement of field strength using calibrated equipment
- D. **All these choices are correct**

One of the factors to consider when performing an RF exposure evaluation is *duty cycle*. Duty cycle is defined as the percentage of time that a transmitter is transmitting. Duty cycle is important because it affects a person's average exposure to RF radiation. A transmission with a duty cycle of 50% is less hazardous than a transmission with a duty cycle of 100% because the transmitter would be generating RF radiation for only half the time.

T0C11

What is the definition of duty cycle during the averaging time for RF exposure?

- A. The difference between the lowest and highest power output of a transmitter
- B. The difference between the PEP and the average power output of a transmitter
- C. The percentage of time that a transmitter is transmitting**
- D. The percentage of time that a transmitter is not transmitting

T0C10

Why is duty cycle one of the factors used to determine safe RF radiation exposure levels?

- A. It affects the average exposure to radiation**
- B. It affects the peak exposure to radiation
- C. It takes into account the antenna feed line loss
- D. It takes into account the thermal effects of the final amplifier

T0C03

How does the allowable power density for RF safety change if duty cycle changes from 100 percent to 50 percent?

- A. It increases by a factor of 3
- B. It decreases by 50 percent
- C. It increases by a factor of 2**
- D. There is no adjustment allowed for lower duty cycle

Because of the way radio waves interact with the body, the exposure limits are different for each amateur radio band. Oddly, 50 MHz is the frequency at which the human body absorbs the most radiation. In addition to the frequency and power level of the RF field, the distance from an amateur station antenna and radiation pattern of the antenna affect how much RF exposure that people will experience near the antenna.

T0C05

Why do exposure limits vary with frequency?

- A. Lower frequency RF fields have more energy than higher frequency fields
- B. Lower frequency RF fields do not penetrate the human body
- C. Higher frequency RF fields are transient in nature
- D. The human body absorbs more RF energy at some frequencies than at others**

T0C02

Which of the following bands has the lowest maximum permissible exposure for RF safety?

- A. 3.5 MHz
- B. 50 MHz**
- C. 440 MHz
- D. 1296 MHz

T0C04

What factors affect the RF exposure of people near an amateur station antenna?

- A. Frequency and power level of the RF field
- B. Distance from the antenna to a person
- C. Radiation pattern of the antenna
- D. All these choices are correct**

So, what should you do if your RF exposure evaluation shows that people are being exposed to excessive RF?

T0C08

Which of the following actions can reduce exposure to RF radiation?

- A. **Relocate antennas**
- B. Relocate the transmitter
- C. Increase the duty cycle
- D. All these choices are correct

You could also lower the power or simply transmit less.

Finally, you should regularly evaluate your station for RF safety.

T0C09

How can you make sure your station stays in compliance with RF safety regulations?

- A. By informing the FCC of any changes made in your station
- B. **By re-evaluating the station whenever an item in the transmitter or antenna system is changed**
- C. By making sure your antennas have low SWR
- D. By using only Underwriter Laboratories approved transmitting equipment

Station setup and operating controls

Station setup

When setting up an amateur radio station, choosing the radio is the most important consideration, but you must also choose a wide range of accessories, such as power supplies and microphones. In addition, how you connect all these pieces of equipment together is important for your station to operate properly.

For example, a transceiver's DC power cable should be made with short, heavy-gauge wires. When transmitting, the transceiver draws a lot of current, and there will be a measurable voltage drop between the power supply and the transceiver. If this voltage drop is too large, the transceiver could malfunction. The reason for this voltage drop is the resistance of the wires connecting the power supply to the transceiver. Short, heavy-gauge wires have a lower resistance than long, thin wires, and will therefore, cause a lower voltage drop.

T4A03

Why are short, heavy-gauge wires used for a transceiver's DC power connection?

- A. To minimize voltage drop when transmitting
- B. To provide a close match to the power supply output impedance
- C. To avoid RF interference
- D. To minimize radiative losses in the power cable

When choosing a power supply, check the voltage and current ratings of the supply and be sure to choose one capable of supplying the proper voltage and current to power your radio. Let's look at an example.

T4A01

Which of the following is an appropriate power supply rating for a typical 50-watt output mobile FM transceiver?

- A. 24.0 volts at 4 amperes
- B. 13.8 volts at 4 amperes
- C. 24.0 volts at 12 amperes
- D. **13.8 volts at 12 amperes**

There are two reasons why D is the correct answer. First, most mobile FM transceivers are designed to operate with a supply voltage between 11 V and 15 V. That means that the correct answer has to be either B or D. Second, B is incorrect because transceivers are 50% efficient at best, meaning that a 50 W output transceiver will need at least 100 W of power to operate correctly. A supply providing 13.8 V at 4 amperes is supplying only 55 W of power ($P = E \times I = 13.8 \times 4 = 55.2 \text{ W}$), so this supply would be under-powered. That leaves D—13.8 volts at 12 amperes—as the correct answer.

A computer has become a common accessory in many amateur radio stations. Amateurs use them to operate digital modes, log contacts, and design circuits and antennas. I even use mine to Twitter while I'm on the air. When operating digital modes, such as FT8, you connect the transceiver's receive audio, transmit audio, and transmitter keying to a computer. The transceiver audio output, such as the speaker connection, connects to the computer "line in." Similarly, the transceiver audio input connects to the "line out" of the

computer.

T4A06

What signals are used in a computer-radio interface for digital mode operation?

- A. Receive and transmit mode, status, and location
- B. Antenna and RF power
- C. Receive audio, transmit audio, and transmitter keying**
- D. NMEA GPS location and DC power

T4A04

How are the audio input and output of a transceiver connected in a station configured to operate using FT8?

- A. To a computer running a terminal program and connected to a terminal node controller unit
- B. To the audio input and output of a computer running WSJT-X software**
- C. To an FT8 conversion unit, a keyboard, and a computer monitor
- D. To a computer connected to the FT8converter.com website

T4A07

Which of the following is one of the connections required between a computer and a transceiver to operate digital modes?

- A. Computer “line out” to transceiver push-to-talk
- B. Computer “line in” to transceiver push-to-talk
- C. Computer “line in” to transceiver speaker connector**
- D. Computer “line out” to transceiver speaker connector

Good grounding techniques can help you avoid interference problems. When grounding your equipment, you should connect the various pieces of equipment to a single point, keep leads short, and use flat copper strap to connect that point to ground. We sometimes call this process *bonding*.

T4A08

Which of the following conductors is preferred for bonding at RF?

- A. Copper braid removed from coaxial cable
- B. Copper-clad steel wire
- C. Twisted-pair cable
- D. Flat copper strap**

If you plan to install a radio in your car and operate mobile, you have a different set of challenges. One of these challenges is how to connect your radio to the car’s power system. Some amateurs power their radio a 12-volt auxiliary power jack, but this jack is not designed for high currents. For permanent installations, you need to connect the negative power return to the 12 volt battery chassis ground.

T4A11

Where should the negative power return of a mobile transceiver be connected in a vehicle?

- A. At the 12 volt battery chassis ground**
- B. To the shell of the power connector
- C. To any metal part of the vehicle

D. Through the transceiver's mounting bracket

The positive connection can be made at the battery or through an unused position of the vehicle's fuse block.

You can also operate your equipment from a battery when operating portable or at home should the power be off. Of course, batteries have a finite life, and the more current you draw from the battery, the faster it will discharge. To determine how long you can operate using battery power, divide the battery ampere-hour rating by the average current draw of the equipment. For example, if you have a 10 amp-hour battery, and the average current draw is 1 amp, then you can operate for approximately 10 hours: $\text{operating time} = 10 \text{ amp-hours} / 1 \text{ amp} = 10 \text{ hours}$.

T4A09

How can you determine the length of time that equipment can be powered from a battery?

A. Divide the watt-hour rating of the battery by the peak power consumption of the equipment

B. Divide the battery ampere-hour rating by the average current draw of the equipment

C. Multiply the watts per hour consumed by the equipment by the battery power rating

D. Multiply the square of the current rating of the battery by the input resistance of the equipment

Operating controls

To properly operate a transceiver, you need to know how to use the controls. Perhaps the most important transmitter control is microphone gain. Setting the gain too high will result in distorted audio.

T4B01

What is the effect of excessive microphone gain on SSB transmissions?

- A. Frequency instability
- B. Distorted transmitted audio**
- C. Increased SWR
- D. Sideband inversion

You also need to know how to properly set the operating frequency of your transceiver. One reason for this is that setting the frequency of an FM receiver above or below a signal's frequency will result in distorted receive audio.

T4B04

What does an FM signal sound like when received slightly off frequency?

- A. The audio increases in pitch
- B. The audio decrease in pitch
- C. There is no effect except for reduction in amplitude
- D. The audio becomes distorted**

Many modern transceivers allow you to set the operating frequency in several different ways:

- Punching in a number on a keypad.
- Rotating the VFO knob.
- Storing it in a memory channel and then recalling it for quick access.

T4B02

Which of the following can be used to enter a transceiver's operating frequency?

- A. The keypad or VFO knob**
- B. The CTCSS or DTMF encoder
- C. The Automatic Frequency Control
- D. All these choices are correct

Transceivers that allow you to store frequencies in memory often have the ability to step through those frequencies, one at a time, stopping when a signal is received. This is called *scanning* and allows you to tune through a range of frequencies to check for activity.

T4B05

What does the scanning function of an FM transceiver do?

- A. Checks incoming signal deviation
- B. Prevents interference to nearby repeaters
- C. Tunes through a range of frequencies to check for activity**
- D. Tunes through a range of frequencies to determine the antenna's resonant frequency

A common receiver control on VHF/UHF transceivers is the squelch control. Its purpose is to mute the

receiver audio unless you are receiving a signal above a set signal strength.

T2B13

What is the purpose of a squelch function?

- A. Reduce a CW transmitter's key clicks
- B. Mute the receiver audio when a signal is not present**
- C. Eliminate parasitic oscillations in an RF amplifier
- D. Reduce interference from impulse noise

T4B03

How is squelch adjusted so that a weak FM signal can be heard?

- A. Set the squelch threshold so that receiver output audio is on all the time**
- B. Turn up the audio level until it overcomes the squelch threshold
- C. Turn on the anti-squelch function
- D. Enable squelch enhancement

Another common setting on VHF/UHF transceivers is the offset frequency. This is especially important when operating repeaters. This setting specifies the difference between the repeater's transmit frequency and receive frequency.

T2A07

What does the term "repeater offset" mean?

- A. The difference between a repeater's transmit and receive frequencies**
- B. The repeater has a time delay to prevent interference
- C. The approximately half-second delay to allow for the "squelch tail" to be removed
- D. The fee charged by the repeater owner or club to provide for maintenance

In recent years, radios that digitize one's voice and then send the digitized voice over the air have become quite popular. The operating modes that these radios use are called *digital modes*. Two of the most popular digital modes are DMR (Digital Mobile Radio) and D-STAR (Digital Smart Technology for Amateur Radio).

One of the reasons digital modes are so popular is that the digitized voice information can not only be transmitted over the air, but also over the internet. To connect to other radio amateurs over the internet, digital mode radios can use a repeater that is connected to the internet or a *digital mode hot spot* that connect to the internet via a personal computer or smart phone with an internet connection.

T4A10

What function does a digital mode hot spot perform for nearby transceivers?

- A. Communication using digital voice or data network**
- B. FT8 digital communications via AFSK using a smartphone connected to the internet
- C. RTTY encoding and decoding without a computer
- D. High-speed digital communications for meteor scatter

DMR has a feature called *talkgroups*. Talk groups are virtual channels, and when you access a talkgroup, your signal is routed to other radio amateurs who have also accessed that talkgroup, no matter where in the world they are. To use this feature, you must program your radio to properly access repeaters and the talkgroups. This programming information is contained in a DMR radio's *code plug*.

T2B14

Which of the following is a “talkgroup”?

- A. group of amateur radio operators who share email on a specific amateur radio topic
- B. An identifier used by DMR to organize radio traffic so that those who want to hear the group aren't bothered by other radio traffic**
- C. The members of a net organized for amateur radio operators with a specific common interest
- D. A method of automatically alerting all group members to the frequency where any member is transmitting

T2B07

How can you join a digital repeater's “talkgroup”?

- A. Register with the local Frequency Coordinator
- B. Register with the digital repeater control operator
- C. Program your radio with the group's ID or code**
- D. Program your radio with the DTMF tone used by the talkgroup

T4B07

What is a DMR “code plug”?

- A. An adapter cable used to connect a DMR radio to a computer for internet access
- B. Configuration data loaded onto your radio to access repeaters and talkgroups**
- C. An upgrade to DMR programming software provided by the radio manufacturer to accommodate new radio models
- D. A Coder-Decoder (CODEC) that converts analog voice data to DMR digital data and vice versa

T4B09

How is a specific group of stations selected on a DMR digital voice transceiver?

- A. By retrieving the frequencies from transceiver memory
- B. By enabling the group's CTCSS tone
- C. By entering the group's identification code**
- D. By inserting a five-pin, pre-programmed code plug

One of the bits of information that you enter into the code plug is the *color code*.

T2B12

What is the digital color code used on DMR repeater systems?

- A. An access code which must be programmed into a DMR transmitter to access a specific repeater**
- B. A code which automatically programs the repeater offset to a frequency chosen by the user
- C. A code which identifies the specific CODEC being used so that the repeater can properly decode the audio
- D. A code transmitted by the repeater to indicate health and status of the equipment

Part of the information sent when you use a digital voice transceiver, be it a DMR or D-STAR radio, is your call sign. Before you use the radio, you must program the radio with your call sign.

T4B11

Which of the following must be programmed into a D-STAR digital transceiver before transmitting?

- A. Your call sign**

- B. Your output power
- C. The codec type being used
- D. All these choices are correct

HF transceivers have many controls not found on VHF/UHF FM transceivers. For example, they are often equipped with a variety of different filters. The reason for this is that using the appropriate filter for the mode you are operating can make operating a lot easier.

T4B08

What is the advantage of having a choice of receiver filter bandwidths in a multimode transceiver?

- A. Permits monitoring several modes simultaneously by selecting a separate filter for each mode
- B. Permits noise or interference reduction by selecting a bandwidth matching the mode**
- C. Increases the number of frequencies that can be stored in memory
- D. Increases the amount of offset between receive and transmit frequencies

T4B10

Which of the following receiver filter bandwidths provides the best signal-to-noise ratio for SSB reception?

- A. 500 Hz
- B. 1000 Hz
- C. 2400 Hz**
- D. 5000 Hz

A common receiver control on HF transceivers is the Receiver Incremental Tuning, or RIT, control. Its purpose is to set the receive frequency slightly off from the transmit frequency. On some radios, this control is called the *clarifier*.

T4B06

Which of the following controls could be used if the voice pitch of a single-sideband signal returning to your CQ call seems too high or low?

- A. The AGC or limiter
- B. The bandwidth selection
- C. The tone squelch
- D. The RIT or Clarifier**

A common transmitter control is push-to-talk, or PTT. Most of the time PTT refers to an actual switch on the microphone that an operator must push to begin transmitting, but it also refers to the name of a signal line on a transceiver's accessory socket that can be used to automatically switch a transceiver into transmit mode.

T7A07

What is the function of a transceiver's PTT input?

- A. Input for a key used to send CW
- B. Switches transceiver from receive to transmit when grounded**
- C. Provides a transmit tuning tone when grounded
- D. Input for a preamplifier tuning tone

Station equipment

Receivers, transmitters, transceivers, and transverters

In the early days of radio, radio amateurs used separate receivers and transmitter units. Nowadays, however, most use radios that combine function both as the transmitter and receiver. These units are called transceivers.

T7A02

What is a transceiver?

- A. **A device that combines a receiver and transmitter**
- B. A device for matching feed line impedance to 50 ohms
- C. A device for automatically sending and decoding Morse code
- D. A device for converting receiver and transmitter frequencies to another band

Often, HF transceivers are used with devices called transverters that convert the signals from an HF transceiver to the VHF, UHF, and even microwave bands. Transverters take the output of an HF transceiver, normally set to the 10-meter (28 MHz) band and output a VHF, UHF, or microwave signal. Conversely, they receive a VHF, UHF, or microwave signal and output a signal in the 10-meter band that is demodulated by the HF transceiver.

T7A06

What device converts the RF input and output of a transceiver to another band?

- A. High pass filter
- B. Low-pass filter
- C. **Transverter**
- D. Phase converter

Sometimes, you may need more power than your transceiver provides. For example, most new amateurs buy a handheld transceiver, called an “HT,” as their first transceiver, and most HTs have a maximum output power of 5 W, which limits their range. To increase the range, you can add an RF power amplifier to increase the power.

T7A10

What can be added to the output of a transceiver to increase the transmitted output power?

- A. A potentiometer
- B. **An RF power amplifier**
- C. An impedance multiplier
- D. All these choices are correct

VHF power amplifiers that amplify SSB signals operate differently from amplifiers that amplify FM signals. There are some VHF power amplifiers, however, that can amplify both types of signals. This type of amplifier will have a switch that allows you to select either SSB mode or CW-FM mode. It's important to select the correct mode if the amplifier is to operate correctly.

T7A09

What is the function of the switch which selects either SSB or CW-FM on some VHF power amplifiers?

- A. Change the mode of the transmitted signal
- B. Set the amplifier for proper operation in the selected mode**
- C. Change the frequency range of the amplifier to operate in the proper segment of the band
- D. Reduce the received signal noise

When talking about a transceiver's specifications, we still refer to its receiver and transmitter. The two most important receiver specifications are sensitivity and selectivity.

T7A01

Which term describes the ability of a receiver to detect the presence of a signal?

- A. RF gain
- B. Sensitivity**
- C. Selectivity
- D. Total Harmonic Distortion

T7A04

Which term describes the ability of a receiver to discriminate between multiple signals?

- A. Discrimination ratio
- B. Sensitivity
- C. Selectivity**
- D. Harmonic distortion

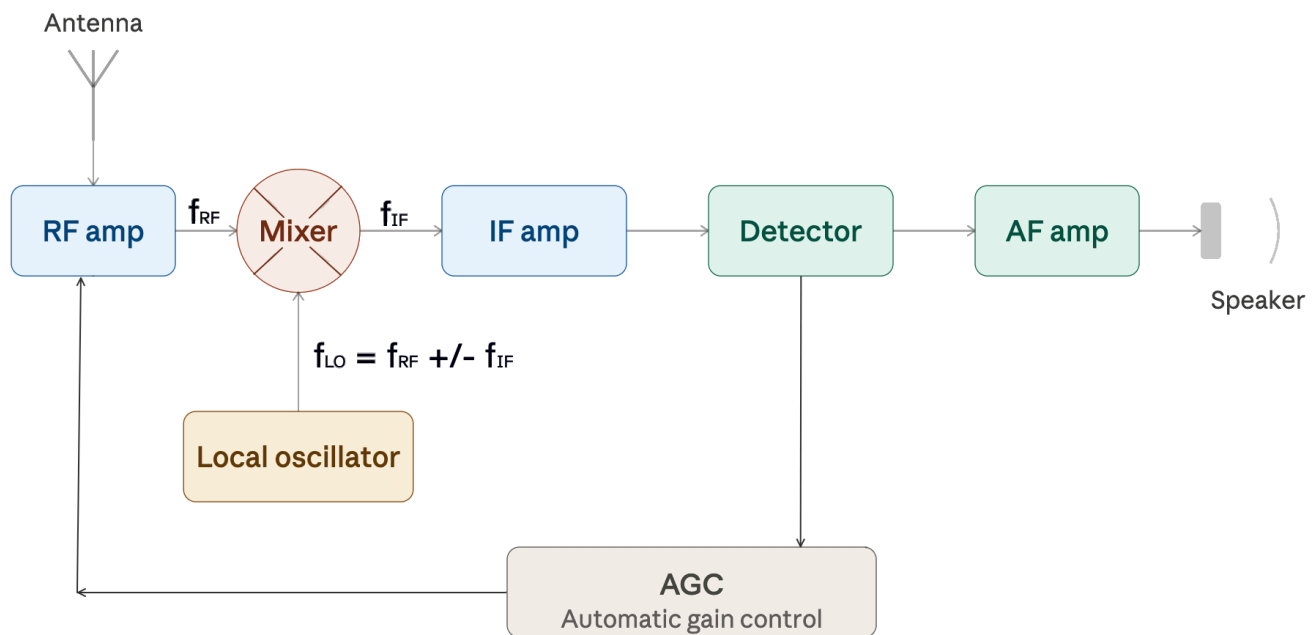

A block diagram of a superheterodyne receiver.

Many HF transceivers have some version of a superheterodyne receiver. As shown in the figure above, the mixer in a superheterodyne receiver combines an incoming radio signal, f_{RF} , with a signal from a local oscil-

lator and converts it to an intermediate frequency, or f_{IF} . The local oscillator generates a signal at a specific frequency, f_{LO} , that is either above or below the incoming signal, so that when combined in the mixer, it produces an output signal equal to f_{IF} .

T7A03

Which of the following is used to convert a signal from one frequency to another?

- A. Phase splitter
- B. Mixer**
- C. Inverter
- D. Amplifier

T7A05

What is the name of a circuit that generates a signal at a specific frequency?

- A. Reactance modulator
- B. Phase modulator
- C. Low-pass filter
- D. Oscillator**

If the local oscillator is variable, that is to say that the oscillator is a variable frequency oscillator (VFO), the receive frequency can be set to any frequency within a particular range. VFOs are also used to set the transmit frequency in an amateur radio transmitter.

T7A11

What is the function of the Variable Frequency Oscillator (VFO) circuit in a transceiver?

- A. Set the receive and transmit frequency**
- B. Provide automatic frequency control
- C. Inject a variable frequency to allow CW reception
- D. Generate and demodulate single sideband signals

Symptoms, causes, and cures of common transmitter and receiver problems

Since Murphy's Law—the law that states if anything can go wrong, it will—applies to amateur radio as much as it does to any other pursuit, at some point you will have to deal with problems. These may include overload, distortion, feedback, and radio frequency interference, or RFI.

Let's first consider radio frequency interference.

T7B03

Which of the following can cause radio frequency interference?

- A. Fundamental overload
- B. Harmonics
- C. Spurious emissions
- D. All these choices are correct**

Any of these could cause interference to a TV set or radio or even computer speakers, and you will want to take steps to find and eliminate that interference. The first thing that you should do if your neighbor complains about interference is to make sure that your station is functioning properly by making sure that your transmissions do not cause interference to your radios or televisions.

T7B06

Which of the following actions should you take if a neighbor tells you that your station's transmissions are interfering with their radio or TV reception?

- A. **Make sure that your station is functioning properly and that it does not cause interference to your own radio or television when it is tuned to the same channel**
- B. Immediately turn off your transmitter and contact the nearest FCC office for assistance
- C. Install a harmonic doubler on the output of your transmitter and tune it until the interference is eliminated
- D. All these choices are correct

While it's not very likely that your amateur radio station will interfere with a neighbor's cable TV service, it can sometimes occur. If you are interfering with a neighbor's cable TV service, first check the coax connectors.

T7B09

What should be the first step to resolve non-fiber optic cable TV interference caused by your amateur radio transmission?

- A. Add a low-pass filter to the TV antenna input
- B. Add a high-pass filter to the TV antenna input
- C. Add a preamplifier to the TV antenna input
- D. **Be sure all TV feed line coaxial connectors are installed properly**

Your amateur radio station may interfere with a nearby radio receiver if your signal is so strong that the receiver cannot reject the signal even though your signal is not on the frequency to which the receiver is tuned. This is called fundamental overload.

T7B02

What would cause a broadcast AM or FM radio to receive an amateur radio transmission unintentionally?

- A. **The receiver is unable to reject strong signals outside the AM or FM band**
- B. The microphone gain of the transmitter is turned up too high
- C. The audio amplifier of the transmitter is overloaded
- D. The deviation of an FM transmitter is set too low

To reduce or eliminate fundamental overload, you can install a filter at the radio or TV input to block the interfering signal.

T7B05

Which of the following might reduce interference by an amateur station to a non-amateur over-the-air radio receiver?

- A. **Block the amateur signal with a filter at the antenna input of the affected receiver**
- B. Block the interfering signal with a filter on the amateur transmitter
- C. Switch the transmitter from FM to SSB
- D. Switch the transmitter to a narrow-band mode

The process can work the other way, too. When driving by the antenna of a high-power broadcast station you may notice that your VHF transceiver is picking up the broadcast station signal. This is often the result of overload. To reduce this interference, you may want to install a *band-reject filter* designed to attenuate signals in the FM broadcast band.

T7B07

Which of the following can reduce interference to a 2-meter band transceiver from a nearby commercial FM station?

- A. Installing an RF preamplifier
- B. Using double-shielded coaxial cable
- C. Installing bypass capacitors on the microphone cable
- D. Installing a band-reject filter**

Interference works both ways. Your neighbors may have wireless devices that can interfere with your station. While they are responsible for eliminating the interference, chances are they don't have the expertise necessary to find and eliminate the interference, so your best option is to try and work with them.

T7B08

What should you do if something in a neighbor's home is causing harmful interference to your amateur station?

- A. Work with your neighbor to identify the offending device
- B. Politely inform your neighbor that FCC rules prohibit the use of devices that cause interference
- C. Make sure your station meets the standards of good amateur practice
- D. All these choices are correct**

Perhaps the most common problem that amateur radio operators have is distorted or noisy audio when transmitting. There are many reasons for poor audio.

T7B10

What might be a problem if you receive a report that your audio signal through an FM repeater is distorted or unintelligible?

- A. Your transmitter is slightly off frequency
- B. You are speaking too loudly or too close to the microphone
- C. You are in a bad location
- D. All these choices are correct**

Speaking too loudly or too close to the microphone can cause over-deviation. Fortunately, there's an easy fix. Simply talk farther away from the microphone.

T7B01

What can you do if you are told your FM handheld or mobile transceiver is over-deviating?

- A. Talk louder into the microphone
- B. Let the transceiver cool off
- C. Change to a higher power level
- D. Talk farther away from the microphone**

Another problem that can cause distorted audio is RF feedback. This can occur if a transmitted signal is being picked up by the microphone cable. To eliminate this feedback, you can add a clip-on ferrite choke to the microphone cable.

T7B11

Which of the following can eliminate distorted voice transmissions?

A. Adding extra feedline to the antenna to lower SWR

B. Turning the radio on and off to reset the computer-controlled circuitry

C. Adding a clip-on ferrite “choke” to the microphone cable to prevent the transmitted signal from feeding back into the transmitter

D. Turning the squelch control fully clockwise to prevent the transmitted signal from triggering the squelch circuit

Using basic test instruments and soldering

The most common test instrument in an amateur radio shack is the multimeter. Multimeters are called that because they combine the functions of a voltmeter, ohmmeter, and ammeter into a single instrument.

T7D07

Which of the following measurements are made using a multimeter?

- A. Signal strength and noise
- B. Impedance and reactance
- C. Voltage and resistance**
- D. All these choices are correct

The voltmeter function of the multimeter is used to measure electric potential, more commonly known as voltage. You measure the voltage across a component or circuit by connecting the leads in parallel with the component.

T7D01

Which instrument would you use to measure electric potential?

- A. An ammeter
- B. A voltmeter**
- C. A potentiometer
- D. An ohmmeter

T7D02

How is a voltmeter connected to a component to measure applied voltage?

- A. In series
- B. In parallel**
- C. In quadrature
- D. In phase

In order to avoid damaging the multimeter, make sure that it's set to the voltage setting, not the resistance setting when you want to measure voltage.

T7D06

Which of the following can damage a multimeter?

- A. Attempting to measure resistance using the voltage setting
- B. Failing to connect one of the probes to ground
- C. Attempting to measure voltage when using the resistance setting**
- D. Not allowing it to warm up properly

If you are going to be measuring high voltages, make sure that the voltmeter and leads are rated for those voltages. Failure to do so is unsafe and could result in damaging the meter.

T0A12

Which of the following precautions should be taken when measuring high voltages with a voltmeter?

- A. Ensure that the voltmeter has very low impedance
- B. Ensure that the voltmeter and leads are rated for use at the voltages being measured**
- C. Ensure that the circuit is grounded through the voltmeter

D. Ensure that the voltmeter is set to the correct frequency

The ohmmeter function of a multimeter is used to measure resistance. The way an ohmmeter measures the resistance of a circuit is by supplying a small, known current to the circuit, measuring the voltage across the circuit, and then calculating the resistance using Ohm's Law, $R = V/I$. Because we're actually measuring voltage, we connect an ohmmeter in parallel with a component to measure its resistance.

T7D05

How does an ohmmeter measure the resistance of a circuit or component?

- A. **By applying a small current and measuring the resulting voltage**
- B. By placing a variable resistor in parallel with the circuit
- C. By placing a variable resistor in series with the circuit
- D. By applying a variable voltage and measuring the resulting current change

T7D11

Which of the following precautions should be taken when measuring in-circuit resistance with an ohmmeter?

- A. Ensure that the applied voltages are correct
- B. **Ensure that the circuit is not powered**
- C. Ensure that the circuit is grounded
- D. Ensure that the circuit is operating at the correct frequency

T7D10

What reading indicates that an ohmmeter is connected across a large, discharged capacitor?

- A. **Increasing resistance with time**
- B. Decreasing resistance with time
- C. Steady full-scale reading
- D. Alternating between open and short circuit

The ammeter function of a multimeter is used to measure current. You connect an ammeter in series with a circuit so that the current flowing through the circuit also flows through the ammeter.

T7D04

Which instrument is used to measure electric current?

- A. An ohmmeter
- B. An electrometer
- C. A voltmeter
- D. **An ammeter**

T7D03

When configured to measure current, how is a multimeter connected to a component?

- A. **In series**
- B. In parallel
- C. In quadrature
- D. In phase

In addition to knowing how to make electrical measurements, knowing how to solder is an essential skill for amateur radio operators.

T7D08

Which of the following types of solder should not be used for radio and electronic applications?

- A. **Acid-core solder**
- B. Lead-tin solder
- C. Rosin-core solder
- D. Tin-copper solder

Using acid-core solder could leave an acidic residue that will degrade the connection over time.

T7D09

What is the characteristic appearance of a cold tin-lead solder joint?

- A. Dark black spots
- B. A bright or shiny surface
- C. **A rough or lumpy surface**
- D. A greenish tinge

We call a poor solder joint a “cold” solder joint because it's usually the result of not applying enough heat to the joint. When you don't apply enough heat to a solder joint, the solder does not flow smoothly between the metal surfaces to be joined and often does not make a good connection.

Operating procedures

FM Operation

Most Technicians purchase a VHF/UHF FM transceiver as their first amateur radio. This type of radio allows them to use repeaters and participate in public-service events.

T1F09 [97.3(a)(40)]

What type of amateur station simultaneously retransmits the signal of another amateur station on a different channel or channels?

- A. Beacon station
- B. Remote control station
- C. Repeater station**
- D. Message forwarding station

Some repeater systems use remote receivers. Remote receivers increase the range of the repeater system by receiving signals that may be too weak for the main repeater to hear. The remote receiver, which is an example of an auxiliary station, relays the signals that they receive to the main repeater for re-transmission.

T1D07 [97.113(d), 97.201(e)]

Which of the following is an example of an auxiliary station?

A. A station sending one-way transmissions between a remote repeater receiver and the main repeater transmitter

- B. A backup radio for emergency use in case the main station radio fails
- C. A station used in the Military Auxiliary Radio System for linking government and amateur stations in a digital network
- D. A second station utilized in multi-operator contest stations

Another way to increase the range of a repeater system is to link a repeater to other repeaters via an RF link, a phone line, or over the internet. When repeaters are linked, a signal received by one repeater is retransmitted by all the other repeaters in the network. This can give the repeater network extremely wide coverage.

T2B03

Which of the following describes a linked repeater network?

A. A network of repeaters in which signals received by one repeater are transmitted by all the repeaters in the network

- B. A single repeater with more than one receiver
- C. Multiple repeaters with the same control operator
- D. A system of repeaters linked by APRS

To use repeaters, you need to know how to set up your radio. Repeaters receive on one frequency and transmit on another. You program your radio so that it receives on the repeater's transmit frequency and transmits on the repeater's receive frequency. The difference between the transmit frequency and receive frequency is called the repeater frequency offset. The frequency offset for 2-meter repeaters is most often 600 kHz, while the most common repeater frequency offset in the 70-cm band is 5 MHz.

T2A01

What is a common repeater frequency offset in the 2-meter band?

- A. Plus or minus 5 MHz
- B. Plus or minus 600 kHz**
- C. Plus or minus 500 kHz
- D. Plus or minus 1 MHz

T2A03

What is a common repeater frequency offset in the 70-cm band?

- A. Plus or minus 5 MHz**
- B. Plus or minus 600 kHz
- C. Plus or minus 500 kHz
- D. Plus or minus 1 MHz

Because repeaters often operate in environments where there is a lot of interference, they are programmed not to repeat a signal unless the signal has a sub-audible tone of a specific frequency. These tones are sometimes called PL (short for “private line”) tones. PL is a Motorola trademark. The generic term for these tones is CTCSS (short for “continuous tone-coded squelch system”). If your radio has not been programmed to transmit the proper sub-audible tone when you transmit, the repeater will not repeat your transmission.

T2B02

What term describes the use of a sub-audible tone transmitted along with normal voice audio to open the squelch of a receiver?

- A. Carrier squelch
- B. Tone burst
- C. DTMF
- D. CTCSS**

A frequent problem is being able to hear a repeater, but not being able to access it. There could be several reasons for this.

T2B04

Which of the following could be the reason you are unable to access a repeater whose output you can hear?

- A. Improper transceiver offset
- B. You are using the wrong CTCSS tone
- C. You are using the wrong DCS code
- D. All these choices are correct**

A Digital Code Squelch, or DCS, tone is similar to a CTCSS tone in that it is sub-audible and opens the squelch of a repeater when a station is trying to access it. They are, however, not very common.

If a station does not have a good signal into a repeater, you may want to listen for it on the repeater input frequency. One way to listen to the repeater input frequency would be to use the reverse function of your VHF/UHF transceiver, if it has this feature. When enabled, the reverse function will cause your transceiver to transmit on the repeater output frequency and receive on the input frequency.

T2B01

]

- A. To reduce power output
- B. To increase power output
- C. To listen on a repeater's input frequency**
- D. To listen on a repeater's output frequency

Another problem you may encounter when operating FM is over-deviation. Over-deviation occurs when the amplitude of the audio modulating the transmitter is too high. This can happen if you speak too loudly into the microphone. This will cause your signal to deviate too much, and that can cause distortion.

T2B05

What of the following would cause your FM transmission audio to be distorted on voice peaks?

- A. Your repeater offset is inverted
- B. Your FM deviation is too low
- C. You are talking too loudly**
- D. Your transmit power is too high

In addition to knowing how to set the controls of your radio, you need to know the protocol for making contacts. When using a repeater, the protocol is very simple. To make contact with another station via a repeater, simply say the station's call sign, then identify by saying your call sign. To indicate that you're listening to a repeater and would like to make contact with another station, say your call sign, then "listening" or "monitoring."

T2A04

What is an appropriate way to call another station on a repeater if you know the other station's call sign?

- A. Say "break, break," then say the station's call sign
- B. Say the station's call sign, then identify with your call sign**
- C. Say "CQ" three times, then the other station's call sign
- D. Wait for the station to call CQ, then answer with your call sign

T2A09

Which of the following is a customary way to indicate a station is listening on a repeater and looking for a contact?

- A. "CQ CQ" followed by the station's call sign
- B. The station's call sign followed by the word "listening"**
- C. The repeater's call sign followed by the station's call sign
- D. "QSY" followed by your call sign

So, for example, if I want to talk to Ralph, AA8RK, on our local repeater, I would say, "AA8RK, KB6NU." If Ralph was listening—and was available to talk—he would then say, "KB6NU, AA8RK," and we would begin our contact. If I wasn't looking for anyone in particular, I would say, "KB6NU listening" or "KB6NU monitoring."

Repeater operation is called duplex operation because you're transmitting and receiving on two different frequencies. When two stations are operating on the same frequency, without the aid of a repeater, it's called simplex operation.

T2A11

What term describes an amateur station that is transmitting and receiving on the same frequency?

- A. Full duplex
- B. Diplex
- C. **Simplex**
- D. Multiplex

On each VHF and UHF band, there are frequencies designated for simplex operation. Operating simplex on these frequencies allows stations to communicate with one another without tying up a repeater.

T2B09

Why are simplex channels designated in the VHF/UHF band plans?

- A. **So stations within range of each other can communicate without tying up a repeater**
- B. For contest operation
- C. For working DX only
- D. So stations with simple transmitters can access the repeater without automated offset

To help amateurs operating simplex find one another, a frequency on each band has been set aside as the "national calling frequency." 146.52 MHz is the national calling frequency for FM simplex operation in the 2 m band.

T2A02

What is the national calling frequency for FM simplex operations in the 2-meter band?

- A. **146.520 MHz**
- B. 145.000 MHz
- C. 432.100 MHz
- D. 446.000 MHz

446.000 MHz is the national calling frequency for the 70 cm band.

HF Operation

On the HF bands, signals can be easy to copy or difficult to copy. Because this is the case, the protocol for making contacts is more complex than the repeater protocol. On HF, when you want to contact another station, you “call CQ.” That is to say, you would say something like, “CQ CQ CQ. This is KB6NU.” This means that you are open to a call from any station.

T2A08

What is the meaning of the procedural signal “CQ”?

- A. A shortened form of the term “Contest QSO”
- B. “Communication Quality,” used to indicate transmitted audio clarity
- C. Only the called station should transmit
- D. **Calling any station**

Knowing how to reply to a CQ is also important. Knowing the commonly accepted protocol will make it easier to make contacts.

T2A05

How should you respond to a station calling CQ?

- A. Transmit “CQ” followed by the other station’s call sign
- B. Transmit your call sign followed by the other station’s call sign
- C. **Transmit the other station’s call sign followed by your call sign**
- D. Transmit a signal report followed by your call sign

For example, if my friend Ralph, AA8RK, heard my call and wanted to talk to me, he would reply, “KB6NU this is AA8RK. Over.” Then, I would return the call, and our contact would begin. If signal conditions are poor, you may want to repeat your call sign and state your call sign in a phonetic alphabet.

It’s important to always identify your station, even when only performing tests.

T1D12 [97.119(a)]

Which of the following is required when making on-the-air test transmissions?

- A. **Identify the transmitting station**
- B. Conduct tests only between 10 p.m. and 6 a.m. local time
- C. Notify the FCC of the transmissions
- D. All these choices are correct

As a Technician, you will be able to operate Morse Code on certain portions of the 80 m, 40 m, 15 m, and 10 m bands. To shorten the number of characters sent during a CW contact, amateurs often use three-letter combinations called Q-signals. Q signals are three-letter combinations, beginning with the letter “Q,” that stand for commonly-used phrases. You need to know the meaning of two of these Q signals: QRM and QSY.

T2B10

Which Q signal indicates that you are receiving interference from other stations?

- A. **QRM**
- B. QRN

- C. QTH
- D. QSB

T2B11

Which Q signal indicates that you are changing frequency?

- A. QRU
- B. **QSY**
- C. QSL
- D. QRZ

FCC rules specify broadly where amateur radio operators have operating privileges, but they are not very detailed. Band plans take this one step further, suggesting where amateurs should use certain modes.

T2A10

What is a band plan, beyond the privileges established by the FCC?

- A. **A voluntary guideline for using different modes or activities within an amateur band**
- B. A list of operating schedules
- C. A list of available net frequencies
- D. A plan devised by a club to indicate frequency band use

While not always adhered to, another basic tenet of amateur radio is to operate courteously and avoid interfering with other stations.

T2B08

Which of the following applies when two stations transmitting on the same frequency interfere with each other?

- A. **The stations should negotiate continued use of the frequency**
- B. Both stations should choose another frequency to avoid conflict
- C. Whichever station was on the frequency first has preemptive rights to the frequency
- D. Use subaudible tones so both stations can share the frequency

Public service and emergency communications

One of the reasons amateur radio exists at all is that ham radio operators are uniquely set up to provide emergency and public-service communications. As a result, many hams consider it an obligation to be prepared to help out when called upon to do so. This includes having the proper equipment and knowing the proper operating procedures. There are two organizations that provide emergency communications: the Radio Amateur Civil Emergency Service (RACES) and the Amateur Radio Emergency Service (ARES).

T2C06

What is the Amateur Radio Emergency Service (ARES)?

A. A group of licensed amateurs who have voluntarily registered their qualifications and equipment for communications duty in the public service

B. A group of licensed amateurs who are members of the military and who voluntarily agreed to provide message handling services in the case of an emergency

C. A training program that provides licensing courses for those interested in obtaining an amateur license to use during emergencies

D. A training program that certifies amateur operators for membership in the Radio Amateur Civil Emergency Service

The Radio Amateur Civil Emergency Service (RACES) is an FCC Part 97 amateur radio service for civil defense communications during national emergencies in the United States. RACES is activated only when a civil defense emergency has been formally declared by an authorized government authority, distinguishing it from similar programs like ARES (Amateur Radio Emergency Service). Participating operators must be licensed amateur radio operators who are also registered as civil defense volunteers with their local emergency management organization.

T2C04

What is RACES?

A. An emergency organization combining amateur radio and citizens band operators and frequencies

B. An international radio experimentation society

C. A radio contest held in a short period, sometimes called a “sprint”

D. An FCC Part 97 amateur radio service for civil defense communications during national emergencies

T2C12

Which of the following requires certification by a civil defense agency?

A. ARES

B. RACES

C. MARS

D. SKYWARN

T1A10 [97.407(a)]

Besides an FCC-issued amateur operator license, what is required to be the control operator of a Radio Amateur Civil Emergency Service (RACES) Station?

A. A written recommendation by the local ARRL Emergency Coordinator

B. Membership in the Amateur Radio Emergency Service (ARES)

C. Certification of current enrollment by a civil defense organization

D. Nothing

When an emergency occurs, it's common for amateur radio operators to form a network or "net" to facilitate emergency communications. The net is led by the net control station, or NCS, whose job includes calling the net to order and directing communications between stations checking in. Stations other than the net control station are said to "check in" to the net.

T2C02

Which of the following are typical duties of a Net Control Station?

- A. Choose the regular net meeting time and frequency
- B. Ensure that all stations checking into the net are properly licensed for operation on the net frequency
- C. **Call the net to order and direct communications between stations checking in**
- D. All these choices are correct

When you check into a net, you must take your lead from the net control station, and transmit only when directed to by the net control station, unless you are reporting an emergency.

T2C07

Which of the following is standard practice when you participate in a net?

- A. When first responding to the net control station, transmit your call sign, name, and address as in the FCC database
- B. Record the time of each of your transmissions
- C. **Unless you are reporting an emergency, transmit only when directed by the net control station**
- D. All these choices are correct

One of the functions of an emergency communications net is to pass messages between stations that have checked into the net. The term for messages passed between stations in a net is "traffic," and the process of passing messages to and from amateur radio stations is called handling traffic. When handling traffic, you should try to pass messages exactly as received. One way to do this is to spell names or unusual words using a standard phonetic alphabet.

T2C05

What does the term "traffic" refer to in net operation?

- A. **Formal messages exchanged by net stations**
- B. The number of stations checking in and out of a net
- C. Operation by mobile or portable stations
- D. A count of the number of activations of the net each month

T2C03

What technique is used to ensure that voice messages containing unusual words are received correctly?

- A. Send the words by voice and Morse code
- B. Use the Q-code "QSR" to ask the receiving station to repeat the words back
- C. **Spell the words using a standard phonetic alphabet**
- D. All these choices are correct

Winlink (formally the Winlink Global Radio Email System) is a worldwide network that enables licensed amateur radio operators to send and receive email messages entirely over radio frequencies, without relying on the internet. Winlink is valuable for emergency and disaster communications, since operators can exchange structured messages, position reports, and even formatted forms with served agencies when normal communications infrastructure is unavailable. Winlink is widely used by ARES, RACES, and other emergency communications groups.

T2C08

Which of the following relays messages using email addresses based on amateur call signs?

- A. Winlink
- B. FT8
- C. PSK31
- D. AMTOR

Formal traffic messages consists of four parts: preamble, address, text, signature. The preamble contains information needed to track the message. Part of the preamble is the check. The check is the number of words or word equivalents in the text portion of the message. Operator use the check to help ensure that a message is received exactly as sent.

T2C10

What information is contained in the preamble of a formal traffic message?

- A. The email address of the originating station
- B. The address of the intended recipient
- C. The telephone number of the addressee
- D. **Information needed to track the message**

T2C11

What is meant by “check” in a radiogram header?

- A. **The number of words or word equivalents in the text portion of the message**
- B. The call sign of the originating station
- C. A list of stations that have relayed the message
- D. A box on the message form that indicates that the message was received and/or relayed

Even in emergencies, you must follow FCC rules when operating an amateur radio station. The normal rules are, however, relaxed a little during true emergencies.

T2C01 [97.103(a)]

When do FCC rules NOT apply to the operation of an amateur station?

- A. When operating under RACES rules
- B. When operating under special FEMA rules
- C. When operating under special ARES rules
- D. **FCC rules always apply**

T2C09

Are amateur station control operators ever permitted to operate outside the frequency

privileges of their license class?

A. No

B. Yes, but only when part of a FEMA emergency plan

C. Yes, but only when part of a RACES emergency plan

D. Yes, but only in situations involving the immediate safety of human life or protection of property

It's kind of a Catch-22. FCC rules always apply to the operation of an amateur radio station, but the rules say that you can do almost anything in a true emergency.

Amateur satellite operation

Making contacts via amateur radio satellites and other space stations is one of the coolest things a ham can do. As a Technician Class licensee, you will have the privileges to do this.

T1B02 [97.301, 97.207(c)]

Which of the following U.S. amateur radio operators are allowed to contact the International Space Station (ISS) on VHF bands?

- A. Only amateurs with a General class or higher license
- B. Any amateurs holding a Technician class or higher license**
- C. Only amateurs with a General class or higher license, and NASA approval
- D. Any amateurs with a Technician class or higher license, and NASA approval

Amateur satellites are basically repeaters in space. As such they have an uplink frequency, which is the frequency on which you transmit and the satellite receives, and a downlink frequency, on which the satellite transmits and you receive. Often, the uplink frequency and downlink frequency are in different amateur bands.

T8B08

What does it mean if a satellite is operating in U/V mode?

- A. The satellite uplink is in the 15-meter band and the downlink is in the 10-meter band
- B. The satellite uplink is in the 70-centimeter band and the downlink is in the 2-meter band**
- C. The satellite operates using ultraviolet frequencies
- D. The satellite frequencies are usually variable

The 70 cm band is in the UHF portion of the spectrum, hence the “U” in U/V, while the 2 meter band is in the VHF portion of the spectrum, hence the “V” in U/V.

While most satellites are FM satellites, some operate using other modes.

T8B04

What mode of transmission is commonly used by amateur radio satellites?

- A. SSB
- B. FM
- C. CW/data
- D. All these choices are correct**

When making contacts via an amateur satellite only use as much power as is needed to make the contact. The reason for this is that when a satellite receives a very strong signal, its automatic gain control (AGC) sets the receive threshold to the level of that signal and weaker signals won't be relayed. When everyone uses a reasonable power level, the AGC doesn't kick in, and the satellite can relay many signals simultaneously.

T8B02

What is the impact of using excessive effective radiated power on a satellite uplink?

- A. Possibility of commanding the satellite to an improper mode
- B. Blocking access by other users**
- C. Overloading the satellite batteries
- D. Possibility of rebooting the satellite control computer

T8B12

Which of the following is a way to determine whether your satellite uplink power into a linear transponder satellite is neither too low nor too high?

- A. Check your signal strength report in the telemetry data
- B. Listen for distortion on your downlink signal
- C. Your signal strength on the downlink should be about the same as the beacon**
- D. Compare your signal to others on the downlink using an internet SDR receiver

Most amateur satellites are in a low Earth orbit, or LEO. Satellites in a low Earth orbit have an altitude between 99 miles and 1,200 miles. This corresponds to an orbital period of around 100 minutes. Satellites in LEO provides high bandwidth and low communication time lag, but they can only be used for a short time when they pass overhead.

T8B10

What does the term LEO mean in reference to communication satellites?

- A. Low Energy Orbit, which conserves battery power
- B. Low Elevation Orbit, which appears close to the horizon from the earth station
- C. Low Equilibrium Orbit, which has a slightly unstable period
- D. Low Earth Orbit, which has a period of around 100 minutes**

Amateur satellites are often equipped with beacons. Beacons often send telemetry signals that inform users about the status of the satellite. Anyone—licensed or not—may receive telemetry from a satellite.

T8B05

What is a satellite beacon?

- A. The primary transmit antenna on the satellite
- B. An indicator light that shows where to point your antenna
- C. A reflective surface on the satellite
- D. A transmission from a satellite that contains status information**

T8B01

What telemetry information is typically transmitted by satellite beacons?

- A. The signal strength of received signals
- B. Time of day accurate to plus or minus 1/10 second
- C. Health and status of the satellite**
- D. All these choices are correct

T8B11

Who is permitted to receive telemetry from an amateur radio satellite?

- A. Anyone**
- B. Only the satellite control operator
- C. Only the control operator or a licensed radio amateur who has received the encryption key from the control operator
- D. Only a licensed radio amateur who has received the encryption key from AMSAT

Computers make it easy to figure out when you can communicate via an amateur satellite. Computer pro-

grams are available that not only tell you when a satellite is passing overhead, but also control an antenna rotor and set the frequency of your transceiver.

T8B03

Which of the following are provided by satellite tracking programs?

- A. Maps showing the real-time position of the satellite track over Earth
- B. The time, azimuth, and elevation of the start, maximum altitude, and end of a pass
- C. The apparent frequency of the satellite transmission, including effects of Doppler shift
- D. **All these choices are correct**

T8B06

Which of the following are inputs to a satellite tracking program?

- A. The satellite transmitted power
- B. **The Keplerian elements**
- C. The last observed time of zero Doppler shift
- D. All these choices are correct

Two issues that you must deal with when communicating via satellites are Doppler shift and spin fading.

T8B07

What is Doppler shift in reference to satellite communications?

- A. A change in the satellite orbit
- B. A mode where the satellite receives signals on one band and transmits on another
- C. **An observed change in signal frequency caused by relative motion between the satellite and Earth station**
- D. A special digital communications mode for some satellites

T8B09

What causes spin fading of satellite signals?

- A. Circular polarized noise interference radiated from the sun
- B. **Rotation of the satellite and its antennas**
- C. Doppler shift of the received signal
- D. Interfering signals within the satellite uplink band

Operating activities

There are many different ways to have fun with amateur radio. Contesting is one of them.

T8C03

What operating activity involves contacting as many stations as possible during a specified period?

- A. Simulated emergency exercises
- B. Net operations
- C. Hidden transmitter hunts
- D. **Contesting**

T8C04

Which of the following is good procedure when contacting another station in a contest?

- A. Signing only the last two letters of your call if there are many other stations calling
- B. Contacting the station twice to be sure that you are in his log
- C. **Sending only the minimum information needed for proper identification and the contest exchange**
- D. Adding "Please copy" before your exchange

Sending the minimum amount of information will help you make as many contacts as possible.

Information about a station's location is often part of the contest exchange. In the U.S., a station's state or ARRL section is most often sent, but in VHF/UHF contests, stations often send each other their grid locators.

T8C05

What is a grid locator?

- A. **A letter-number designator assigned to a geographic location**
- B. A letter-number designator assigned to an azimuth and elevation
- C. An instrument for locating faults in power amplifiers
- D. An instrument for radio direction finding

One activity that is both fun and practical is radio direction finding. You use radio direction finding equipment and skills to participate in hidden transmitter hunts.

T8C01

Which of the following methods is used to locate sources of noise interference or jamming?

- A. Echolocation
- B. Doppler radar
- C. **Radio direction finding**
- D. Phase locking

T8C02

Which of these items would be useful for a hidden transmitter hunt?

- A. Calibrated SWR meter
- B. **A directional antenna**
- C. A directional wattmeter
- D. All these choices are correct

If the only radios that you have are VHF or UHF radios, you might want to look into EchoLink and the Internet Radio Linking Project (IRLP). Both systems provide a way to communicate with amateurs far away with a VHF or UHF transceiver by using Voice Over Internet Protocol (VoIP). The biggest difference between IRLP and EchoLink is that a radio is required to access the IRLP network while you can access the EchoLink network via a computer or mobile device. Because EchoLink has this feature, you must prove that you are a licensed radio amateur before using EchoLink.

T8C08

What is the Internet Radio Linking Project (IRLP)?

- A. **A technique to connect amateur radio systems, such as repeaters, via the internet**
- B. A system for providing access to websites via amateur radio
- C. A system for informing amateurs in real time of the frequency of active DX stations
- D. A technique for measuring signal strength of an amateur transmitter via the internet

T8C07

What is Voice Over Internet Protocol (VoIP)?

- A. A set of rules specifying how to identify your station when linked over the internet to another station
- B. A technique employed to “spot” DX stations via the internet
- C. A technique for measuring the modulation quality of a transmitter using remote sites monitored via the internet
- D. **A method of delivering voice communications over the internet using digital techniques**

T8C10

What is required before using the EchoLink system?

- A. Complete the required EchoLink training
- B. Purchase a license to use the EchoLink software
- C. **Register your call sign and provide proof of license**
- D. At least a General Class license

T8C09

Which of the following protocols enables an amateur station to transmit through a repeater without using a radio to initiate the transmission?

- A. IRLP
- B. D-STAR
- C. DMR
- D. **EchoLink**

Stations that connect to EchoLink or IRLP are called nodes. You can access a particular node by punching in the node number on a radio’s keypad. Pressing keys on the keypad generates DTMF (dual tone, multi-frequency) signals. DTMF signals are comprised of a pair of tones which are unique for each key.

T8C06

How is over the air access to Internet Radio Linking Projects (IRLP) nodes accomplished?

- A. By obtaining a password that is sent via voice to the node
- B. **By using DTMF signals**
- C. By entering the proper internet password

D. By using Continuous Tone-Coded Squelch System (CTCSS) tone codes

T2B06

What type of signaling to a repeater uses two simultaneous audio tones?

- A. DTMF
- B. CTCSS
- C. GMRS
- D. D-STAR

Sometimes, nodes are also gateways.

T8C11

What is an amateur radio station that connects other amateur stations to the internet?

- A. **A gateway**
- B. A repeater
- C. A digipeater
- D. A beacon

Rules and regulations

Part 97 definitions, interference, repeater frequency coordinators, and the ITU

The government agency that is responsible for the Amateur Radio Service in the United States is the Federal Communications Commission (FCC). The FCC regulates and enforces the rules which govern the service in the United States

T1A02 [97.1]

Which agency regulates and enforces the rules for the Amateur Radio Service in the United States?

- A. ARRL
- B. Homeland Security
- C. **The FCC**
- D. All these choices are correct

Part 97 is the part of the radio regulations that govern the Amateur Radio Service. Part 97.1 lists five “purposes” for the existence of amateur radio. The first is recognition of its usefulness in providing emergency and public-service communications. Another is that amateur radio helps people improve their technical skills and operating skills.

T1A01 [97.1]

Which of the following is part of the Basis and Purpose of the Amateur Radio Service?

- A. Providing personal radio communications for as many citizens as possible
- B. Providing communications for international contesting
- C. **Advancing skills in the technical and communication phases of the radio art**
- D. All these choices are correct

Part 97 defines terms and concepts that every amateur radio operator needs to know. One of the definitions is the definition of a space station.

T1A07 [97.3(a)(41)]

What is the FCC Part 97 definition of a space station?

- A. Any satellite orbiting Earth
- B. A manned satellite orbiting Earth
- C. **An amateur station located more than 50 km above Earth's surface**
- D. An amateur station using amateur radio satellites for relay of signals

One of the most important concepts defined by Part 97 is that of harmful interference. Part 97.3(a)(23) defines harmful interference as “Interference which endangers the functioning of a radionavigation service or of other safety services or seriously degrades, obstructs or repeatedly interrupts a radiocommunication service operating in accordance with the Radio Regulations.” Part 97.101(d) says, “No amateur operator

shall willfully or maliciously interfere with or cause interference to any radio communication or signal.”

T1A11 [97.101(d)]

Which of the following is prohibited?

- A. International communications on VHF bands and higher frequencies
- B. Willful or malicious interference**
- C. Third-party traffic using digital modes
- D. All these choices are correct

Part 97 also contains rules about how repeater frequencies are assigned. This responsibility is assigned to regional *frequency coordinators*, who are amateur radio operators who volunteer to do this work and are selected by radio amateurs in that region.

T1A08 [97.3(a)(22)]

Who recommends transmit/receive channels for auxiliary and repeater stations?

- A. A Frequency Spectrum Manager appointed by the FCC
- B. A Volunteer Frequency Coordinator recognized by local amateurs**
- C. An FCC Regional Field Office
- D. The International Telecommunication Union

T1A09 [97.3(a)(22)]

Who selects a Frequency Coordinator?

- A. The FCC Office of Spectrum Management and Coordination Policy
- B. The local chapter of the Office of National Council of Independent Frequency Coordinators
- C. Amateur operators in a local or regional area whose stations are eligible to be repeater or auxiliary stations**
- D. The FCC Regional Field Office

Frequency allocations and power output limits

Because operation outside of the amateur radio bands is a serious offense, it is important to know about the frequencies that amateur radio operators can use, as well as the modes you can use on those frequencies.

T1B03 [97.301(a)]

Which frequency is in the 6-meter amateur band?

- A. 49.00 MHz
- B. **52.525 MHz**
- C. 28.50 MHz
- D. 222.15 MHz

T1B04 [97.301(a)]

Which amateur band includes 146.52 MHz?

- A. 6 meters
- B. 20 meters
- C. 70 centimeters
- D. **2 meters**

T1B06 [97.301(e), 97.305]

On which HF bands does a Technician class operator have phone privileges?

- A. None
- B. **10-meter band only**
- C. 80-meter, 40-meter, 15-meter, and 10-meter bands
- D. 30-meter band only

T1B01 [97.301 (e)]

Which of the following frequency ranges are available for phone operation by Technician licensees?

- A. 28.050 MHz to 28.150 MHz
- B. 28.100 MHz to 28.300 MHz
- C. **28.300 MHz to 28.500 MHz**
- D. 28.500 MHz to 28.600 MHz

T1B10 [97.305(c)]

Where may SSB phone be used in amateur bands above 50 MHz?

- A. Only in sub-bands allocated to General class or higher licensees
- B. Only on repeaters
- C. **In at least some segment of all these bands**
- D. On any band if the power is limited to 25 watts

T1B07 [97.305(a), (c)]

Which of the following VHF/UHF band segments are limited to CW only?

- A. **50.0 MHz to 50.1 MHz and 144.0 MHz to 144.1 MHz**
- B. 219 MHz to 220 MHz and 420.0 MHz to 420.1 MHz
- C. 902.0 MHz to 902.1 MHz
- D. All these choices are correct

T1B05 [97.301, 97.305]

Which of the following bands include frequencies where Technicians are authorized to use digital modes such as FT8?

- A. 10 meters

- B. 6 meters
- C. 2 meters
- D. All these choices are correct**

T1B09 [97.101(a), 97.301(a-e)]

Why should you not set your transmit frequency to be exactly at the edge of an amateur band or sub-band?

- A. To allow for calibration error in the transmitter frequency display
- B. So that modulation sidebands do not extend beyond the band edge
- C. To allow for transmitter frequency drift
- D. All these choices are correct**

Amateur radio operators share some bands with users from other services. Sometimes, amateurs are the primary users, such as in the 2m band, but sometimes amateur radio operators are secondary users. When amateurs are secondary users, they must avoid interfering with the primary users.

T1B08 [97.303]

How are US amateurs restricted in segments of bands where the Amateur Radio Service is secondary?

- A. U.S. amateurs may find non-amateur stations in those segments, and must avoid interfering with them**
- B. U.S. amateurs must give foreign amateur stations priority in those segments
- C. International communications are not permitted in those segments
- D. Digital transmissions are not permitted in those segments

Since Technician Class operators have full amateur privileges above 50 MHz, they can operate transmitters with an output power of up to 1,500 watts at frequencies in the VHF region and above. On the HF bands, however, transmitters operated by Technicians are restricted to an output power of 200 watts or less.

T1B12 [97.313(b)]

Except for some specific restrictions, what is the maximum peak envelope power output for Technician class operators using frequencies above 30 MHz?

- A. 50 watts
- B. 100 watts
- C. 500 watts
- D. 1500 watts**

T1B11 [97.313]

What is the maximum peak envelope power output for Technician class operators in their HF band segments?

- A. 200 watts**
- B. 100 watts
- C. 50 watts
- D. 10 watts

License classes

As you might expect, licensing is a big deal in the Amateur Radio Service. Your class of license determines

where you can operate, and in some cases, what modes you can operate and how much power you can use. While you will find Novice and Advanced Class licensees in the FCC database, only Technician, General, and Amateur Extra Class licenses are currently available from the FCC.

T1C01 [97.9(a), 97.17(a)]

For which classes of amateur radio licenses does the FCC currently issue new licenses?

- A. Novice, Technician, General, Amateur Extra
- B. Technician, Technician Plus, General, Amateur Extra
- C. Novice, Technician Plus, General, Advanced
- D. Technician, General, Amateur Extra**

After you pass the test, the FCC will send you an email notifying you how to pay the \$35 license fee. Once you pay that fee, they will assign you a call sign, enter your information into the license database, and send you an email with a link to download the license grant. The normal term for an FCC-issued amateur radio license is ten years. As soon as your operator/station license grant appears in the FCC's license database, you may transmit on the amateur bands.

T1C08 [97.25]

What is the normal term for an FCC-issued amateur radio license?

- A. Five years
- B. Eight years
- C. Ten years**
- D. Life

T1C10 [97.5a]

How soon after passing the examination for your first amateur radio license may you transmit on the amateur radio bands?

- A. Immediately on receiving your Certificate of Successful Completion of Examination (CSCE)
- B. As soon as your operator/station license grant appears on the ARRL website
- C. As soon as your operator/station license grant appears in the FCC's license database**
- D. As soon as you receive your license in the mail from the FCC

T1A04 [97.23]

How do you receive official notification of your new license and call sign after passing the exam?

- A. Email from the FCC with a link to download the license grant**
- B. USPS First-Class Mail from the FCC
- C. Email from the lead volunteer examiner
- D. USPS First-Class Mail from the lead volunteer examiner

For some time now, the official amateur radio license authorization has been the electronic record that exists in the FCC Universal Licensing System (ULS). Paper licenses are no longer issued as a matter of course, although you can log into the FCC website and print out a paper copy if you so choose.

T1A05 [97.7]

What proves that the FCC has issued an operator/primary license grant?

- A. A printed copy of the certificate of successful completion of examination

- B. An email notification from the NCVEC granting the license
- C. The license appears in the FCC ULS database**
- D. All these choices are correct

After you pass the test, the FCC will assign you a call sign sequentially from the pool of available call signs. If you do not like this call sign, you can apply for a vanity call sign.

T1C02 [97.19]

Who may select a desired call sign under the vanity call sign rules?

- A. Only a licensed amateur with a General or Amateur Extra Class license
- B. Only a licensed amateur with an Amateur Extra Class license
- C. Only a licensed amateur who has been licensed continuously for more than 10 years
- D. Any licensed amateur**

The call sign you select must not only be available, it must have an appropriate format for the class of license you hold. For example, only Amateur Extra class licensees may hold 1x2 or 2x1 call signs. This means that a Technician class amateur radio operator may not choose the call signs KA1X, which is a 2x1 call sign, or W1XX, which is a 1x2 call sign.

T1C05

Which of the following is a valid Group D call sign format for Technician class?

- A. KF1XXX**
- B. KA1X
- C. W1XX
- D. All these choices are correct

If you don't renew your license before it expires, or within the two-year grace period, you will have to take the test again to get a new amateur radio license.

T1C09 [97.21(a)(b)]

What is the grace period for renewal if an amateur license expires?

- A. Two years**
- B. Three years
- C. Five years
- D. Ten years

T1C11 [97.21(b)]

If your license has expired and is still within the allowable grace period, may you continue to transmit on the amateur radio bands?

- A. Yes, for up to two years
- B. Yes, as soon as you apply for renewal
- C. Yes, for up to one year
- D. No, you must wait until the license has been renewed**

Clubs may apply for a station license for their club station, if the club has at least four members. The club

may even apply for a vanity call sign.

T1F11 [97.5(b)(2)]

Which of the following is a requirement for the issuance of a club station license grant?

- A. The trustee must have an Amateur Extra Class operator license grant
- B. The club must have at least four members**
- C. The club must be registered with the American Radio Relay League (ARRL)
- D. All these choices are correct

As of December 2020, applicants for an amateur radio license must provide a valid email address. Should you change that email address, you must inform the FCC of your new address. If the FCC is unable to contact you at the email address on file, they may revoke your license.

T1C04 [97.23]

What may happen if the FCC is unable to reach you by email?

- A. Fine and suspension of operator license
- B. Revocation of the station license or suspension of the operator license**
- C. Revocation of access to the license record in the FCC system
- D. Nothing; there is no such requirement

A question that sometimes arises is what regulations apply in international waters. The answer is that you can operate your station while aboard a ship in international waters if that ship is documented or registered in the United States and you get permission from the ship's master.

T1C06 [97.5(a)(2), 97.11(a)]

Which of the following statements is true about using your amateur radio license when operating aboard a vessel or craft in international waters?

- A. Amateur operation is prohibited in international waters
- B. You may only operate during maritime emergencies
- C. You need special FCC authorization for maritime mobile operation
- D. You may operate from a US-documented vessel with the master's permission**

Authorized and prohibited transmissions

As a licensed radio amateur, it's important to know what you can and can't do on the air. Indecent language is prohibited, and oddly enough, so is music, except for one specific situation.

T1D06 [97.113(a)(4)]

What, if any, are the restrictions concerning transmission of language that may be considered indecent or obscene?

- A. The FCC maintains a list of words that are not permitted to be used on amateur frequencies
- B. Any such language is prohibited**
- C. The International Telecommunications Union (ITU) maintains a list of words that are not permitted to be used on amateur frequencies
- D. There is no such prohibition

T1D04 [97.113(a)(4), 97.113(c)]

Under what conditions is an amateur station authorized to transmit music using a phone emission?

- A. When incidental to an authorized retransmission of manned spacecraft communications**
- B. When the music produces no spurious emissions
- C. When transmissions are limited to less than three minutes per hour
- D. When the music is transmitted above 1280 MHz

Transmitting any codes whose specifications are not published or well-known is prohibited, except when transmitting control commands to space stations or radio control craft. What this means in practice is that encryption is not allowed on the amateur radio bands,

T1D03 [97.211(b), 97.215(b), 97.113(a)(4)]

When is it permissible to transmit messages encoded to obscure their meaning?

- A. Only when using a remote station during a contest
- B. Only when transmitting certain approved digital codes
- C. Only when transmitting control commands to space stations or radio control craft**
- D. Never

Amateur radio stations may only communicate with amateur stations in other countries when that country allows it.

T1D01 [97.111(a)(1)]

With which countries are FCC-licensed amateur radio stations prohibited from exchanging communications?

- A. Any country whose administration has notified the International Telecommunication Union (ITU) that it objects to such communications**
- B. Any country whose administration has notified the American Radio Relay League (ARRL) that it objects to such communications
- C. Any country banned from such communications by the International Amateur Radio Union (IARU)
- D. Any country banned from making such communications by the American Radio Relay

League (ARRL)

Currently, there are no countries that U.S. amateurs are prohibited from contacting, but I'm going to guess that there are no licensed radio amateurs in North Korea.

Another big deal in amateur radio is the prohibition of being paid to operate an amateur radio station, except in some very special circumstances. That doesn't mean that you can't make money from amateur radio. I'm obviously making a few bucks by selling study guides, but I can't be paid for operating my station or someone else's station.

T1D08 [97.113(a)(3)(iii)]

In which of the following circumstances may the control operator of an amateur station receive compensation for operating that station?

- A. When the communication is related to the sale of amateur equipment by the control operator's employer
- B. When the communication is a part of classroom instruction at an educational institution**
- C. When the communication is made to obtain emergency information for a local broadcast station
- D. All these choices are correct

T1D05 [97.113(a)(3)(ii)]

When may amateur radio operators use their stations to notify other amateurs of the availability of equipment for sale or trade?

- A. Never
- B. When the equipment is not the personal property of either the station licensee, or the control operator, or their close relatives
- C. When no profit is made on the sale
- D. When selling amateur radio equipment and not on a regular basis**

Amateur radio stations may not broadcast. The FCC defines broadcasting as one-way transmissions intended for the general public.

T1D10 [97.3(a)(10)]

How does the FCC define broadcasting for the Amateur Radio Service?

- A. Two-way transmissions by amateur stations
- B. Any transmission made by the licensed station
- C. Transmission of messages directed only to amateur operators
- D. Transmissions intended for reception by the general public**

T1D02 [97.113(b), 97.111(b)]

Under which of the following circumstances are one-way transmissions by an amateur station prohibited?

- A. Announcement of upcoming ham radio operating events
- B. Broadcasting**
- C. International Morse Code Practice

D. Telecommand or transmissions of telemetry

Amateurs may, however, transmit information for broadcast by broadcast stations in an emergency situation.

T1D09 [97.113(5)(b)]

When may amateur stations transmit information in support of broadcasting, program production, or news gathering, assuming no other means is available?

A. When such communications are directly related to the immediate safety of human life or protection of property

B. When broadcasting communications to or from the space shuttle

C. Where non-commercial programming is gathered and supplied exclusively to the National Public Radio network

D. Never

So, what is allowed? Well, for one thing, you can talk about amateur radio and other personal topics when making an international contact.

T1C03 [97.117]

What types of international communications are FCC-licensed amateur radio stations permitted to make?

A. Communications incidental to the purposes of the Amateur Radio Service and remarks of a personal character

B. Communications incidental to conducting business or remarks of a personal nature

C. Only communications incidental to contest exchanges; all other communications are prohibited

D. Any communications that would be permitted by an international broadcast station

Control operator and control types

An important concept in amateur radio is the control operator. The basic concept is that an amateur radio station must always have a control operator, and that control operator is responsible for the proper operation of that station. And, the default control operator is the station licensee.

T1E01 [97.7(a)]

When may an amateur station transmit without a control operator?

- A. When using automatic control, such as in the case of a repeater
- B. When the station licensee is away and another licensed amateur is using the station
- C. When the transmitting station is an auxiliary station
- D. **Never**

T1E11 [97.103(a)]

Who does the FCC presume to be the control operator of an amateur station, unless documentation to the contrary is in the station records?

- A. The station custodian
- B. The third party participant
- C. The person operating the station equipment
- D. **The station licensee**

T1E03 [97.103(b)]

Who must designate the station control operator?

- A. **The station licensee**
- B. The FCC
- C. The frequency coordinator
- D. Any licensed operator

T1E07 (D) [97.103(a)]

When the control operator is not the station licensee, who is responsible for the proper operation of the station?

- A. All licensed amateurs who are present at the operation
- B. Only the station licensee
- C. Only the control operator
- D. **The control operator and the station licensee**

T1F10 [97.205(g)]

Who is accountable if a repeater inadvertently retransmits communications that violate the FCC rules?

- A. **The control operator of the originating station**
- B. The control operator of the repeater
- C. The owner of the repeater
- D. Both the originating station and the repeater owner

T1E04 [97.103(b)]

What determines the transmitting frequency privileges of an amateur station?

- A. The frequency authorized by the frequency coordinator
- B. The frequencies printed on the license grant
- C. The highest class of operator license held by anyone on the premises
- D. **The class of operator license held by the control operator**

T1E06 [97.301]

When, other than during an emergency, may a Technician class licensee be the control operator of a station operating in an Amateur Extra Class band segment?

A. At no time

- B. When designated as the control operator by an Amateur Extra Class licensee
- C. As part of a multi-operator contest team
- D. When using a club station whose trustee holds an Amateur Extra Class license

T1E02 [97.301, 97.207(c)]

Who may be the control operator of a station communicating through an amateur satellite or space station?

- A. Only an Amateur Extra Class operator
- B. A General class or higher licensee with a satellite operator certification
- C. Only an Amateur Extra Class operator who is also an AMSAT member
- D. Any amateur allowed to transmit on the satellite uplink frequency**

Two related concepts are the control point and control type. Part 97 defines three control types:

- Local control. A station is said to be locally controlled when the control operator can directly manipulate the controls of an amateur radio station.
- Remote control. A station is said to be remotely controlled when the control operator indirectly manipulates the operating controls of an amateur radio station through a control link, such as a radio link, a telephone link, or an internet link. Any station can be remotely controlled.
- Automatic control. A station is said to be automatically controlled if it uses devices and procedures for control without the control operator being present at the control point.

The control point is where the control function is being performed. For example, the control point of a station that is being locally controlled is wherever the station and operator are located. The control point of a remotely-controlled station is wherever the control operator is located, which could be anywhere in the world, if the operator is controlling the station over the internet.

T1E05 [97.3(a)(14)]

What is an amateur station's control point?

- A. The location of the station's transmitting antenna
- B. The location of the station's transmitting apparatus
- C. The location at which the control operator function is performed**
- D. The mailing address of the station licensee

T1E10 [97.3(a)(39)]

Which of the following is an example of remote control as defined in Part 97?

- A. A software defined radio (SDR)
- B. Operating the station over the internet**
- C. Controlling a model aircraft, boat, or car by amateur radio
- D. Earth-Moon-Earth (EME) communications

T1E09 [97.109(c)]

Which amateur stations may be remotely controlled?

- A. Only repeater stations
- B. Only automatically controlled stations
- C. Only digital stations

D. Any station

T1E08 [97.3(a)(6), 97.205(d)]

Which of the following is an example of automatic control?

- A. **Repeater operation**
- B. Controlling a station over the internet
- C. Using a computer or other device to send CW automatically
- D. Using a computer or other device to identify automatically

Station identification, repeaters, third-party communications, FCC inspection

Proper station identification is also very important. In fact, failure to identify properly is perhaps the most common rule violation.

T1F03 [97.119(a)]

When are you required to transmit your assigned call sign?

- A. At the beginning of each contact, and every 10 minutes thereafter
- B. At least once during each transmission
- C. At least every 15 minutes during and at the end of a communication
- D. At least every 10 minutes during and at the end of a communication**

T1D11 [97.215]

When may an amateur station transmit without identifying on the air?

- A. When the transmissions are of a brief nature to make station adjustments
- B. When the transmissions are unmodulated
- C. When the transmitted power level is below 0.1 watt
- D. When transmitting signals to control model craft**

T1F04 [97.119(b)(2)]

What language must you use for identification when using a phone emission?

- A. Any language recognized by the United Nations
- B. Any language recognized by the ITU
- C. English**
- D. English, French, or Spanish

T1F05 [97.119(b)(2)]

What method of call sign identification is required for a station transmitting phone signals?

- A. Send the call sign followed by the indicator RPT
- B. Send the call sign using a CW or phone emission**
- C. Send the call sign followed by the indicator R
- D. Send the call sign using only a phone emission

T1A03 [97.119(b)(2)]

What do the FCC rules state regarding the use of a phonetic alphabet for station identification in the Amateur Radio Service?

- A. It is required when transmitting emergency messages
- B. It is encouraged when using phone emissions**
- C. It is required when in contact with foreign stations
- D. All these choices are correct

For some types of operations, using a tactical call is allowed. A tactical call describes the function of the station or the location of a station, such as “Race Headquarters.” You do, however, still have to identify using your FCC-assigned call sign every ten minutes or at the end of a communication.

T1F02 [97.119 (a)]

How often must you identify with your FCC-assigned call sign when using tactical call signs such as “Race Headquarters”?

- A. Never, the tactical call is sufficient
- B. Once every hour
- C. At least every 10 minutes during and at the end of a communication**
- D. At the end of every transmission

When operating mobile or portable, or when you wish to note something about your station, you may use a self-assigned call sign indicator, such as “/3,” “mobile,” or “QRP.”

T1F06 [97.119(c)]

Which of the following self-assigned indicators are acceptable when using a phone transmission?

- A. KL7CC stroke W3
- B. KL7CC slant W3
- C. KL7CC slash W3
- D. All these choices are correct**

Third-party communications are communications on behalf of someone who is not the station licensee. For example, if you have a friend over to your house and let him or her talk on your radio, that is a third-party communication. These are entirely legal within the United States, but there are some restrictions when you are in contact with an amateur station in a foreign country.

T1F08 [97.3(a)(47)]

What is the definition of third-party communications?

- A. A message from a control operator to another amateur station control operator on behalf of another person**
- B. Amateur radio communications where three stations are in communications with one another
- C. Operation when the transmitting equipment is licensed to a person other than the control operator
- D. Temporary authorization for an unlicensed person to transmit on the amateur bands for technical experiments

T1F07 (B) [97.115(a)(2)]

Which of the following restrictions apply when a non-licensed person is allowed to speak to a foreign station via a station under the control of an FCC-licensed amateur radio operator?

- A. The person must be a U.S. citizen
- B. The foreign station must be in a country with which the U.S. has a third party agreement**
- C. The licensed control operator must do the station identification
- D. All these choices are correct

Finally—and I do mean finally.

T1F01 [97.103(c)]

When must the station and its records be available for FCC inspection?

A. At any time ten days after notification by the FCC of such an inspection

B. At any time upon request by an FCC representative

C. At any time after written notification by the FCC of such inspection

D. Only when presented with a valid warrant by an FCC official or government agent

They're not going to knock on your door at 3 a.m. some morning to take a look at your shack, but one of your obligations as a licensee is to make your station and your records available when requested to do so.

Well, that's it! We've covered all 413 questions in the Technician Class question pool. Now, you should take some online practice tests, and when you're passing those regularly, find an exam session and get your license. Good luck and 73!

Glossary

AC: alternating current. Alternating current is the name for current that reverses direction on a regular basis. The power outlets in your home provide alternating current.

APRS: Automatic Packet Reporting System. APRS is digital communications system used by amateur radio operators. While it is normally used for tracking the location of mobile stations, it can be used for other purposes as well. For more information, go to <http://www.aprs.org>.

ARES: Amateur Radio Emergency Service. The Amateur Radio Emergency Service consists of licensed amateurs who have voluntarily registered their qualifications and equipment with their local ARES leadership for communications duty in the public service when disaster strikes. For more information, go to <http://www.arrl.org/ares>.

AM: amplitude modulation. The type of modulation that varies the amplitude of a radio signal in accordance with the amplitude of a modulating signal. For more information, go to http://www.pa2old.nl/files/am_fundamentals.pdf.

band plan: plan showing how frequencies within a particular amateur radio band are assigned to different modes so that operators may avoid interfering with one another.

beam antenna: directional antenna.

CTCSS: Continuous Tone Coded Squelch System. A system that uses sub-audible tones, transmitted along with the audio portion of a transmission to control whether or not a repeater will re-transmit a signal. It is known by a number of different trade names, including Private Line® (PL) by Motorola. In practice, it's used to prevent nearby transmitters from inadvertently turning on repeaters.

CW: continuous wave. This is the operating mode amateur radio operators use when sending Morse Code.

DC: direct current. Direct current is the name for current that never reverses direction.

Digital Mobile Radio: radio standard for time-division multiplexing two digital voice signals on a 12.5 KHz repeater channel.

DMR: Digital Mobile Radio

DTMF: dual-tone, multi-frequency. DTMF is a type of signaling used to send data over voice channels. Its most common use in amateur radio is to allow users of handheld transceivers to send commands to repeater systems. It is called DTMF because every time a user presses a keypad button a unique tone consisting of two frequencies is transmitted. For more information, see <http://www.genave.com/dtmf.htm>.

EchoLink: system that links amateur radio stations and computing devices using Voice over IP (VOIP).

electromotive force (EMF): force that propels electric charge through a conductor or circuit; expressed in volts (V).

FCC: Federal Communications Commission. This is the government body which sets the rules for amateur radio in the U.S.

feed line: wire or cable that carries signals from a transmitter to an antenna or from an antenna to a receiver.

FM: frequency modulation. The type of modulation normally used when operating on VHF and UHF repeaters.

FT8: data transmission protocols designed for very weak signal communication.

HF: high frequency. The range of frequencies between 3 MHz and 30 MHz.

HT: handy-talky or handheld transceiver. “Handy Talky” is a Motorola trademark.

ITU: International Telecommunications Union. This is the international body which governs amateur radio worldwide.

LSB: lower sideband. See **SSB**.

modulation: the process of changing the amplitude, frequency, phase, or intensity of an RF signal in accordance with an audio or data input.

MFSK: multi-frequency shift keying. A type of modulation used to send digital information over a radio channel.

PL: Private Line. See **CTCSS**.

PL-259: male connector often used to connect feedlines to a radio.

polarization: orientation of the electric field a radio wave.

PSK: phase shift keying. A method for sending digital information over a radio channel. A popular amateur radio “digital mode” is PSK31, which uses PSK modulation and occupies only 31 Hz of bandwidth.

PTT: push-to-talk

RACES: Radio Amateur Civil Emergency Service. RACES is an amateur radio emergency communications service created by the Federal Emergency Management Agency (FEMA) and the FCC. RACES volunteers serve their respective jurisdictions pursuant to guidelines and mandates established by local emergency management officials. See <http://www.usraces.org/> for more information.

RIT: receiver incremental tuning. A control which allows a user to set the receive frequency of a transceiver either slightly higher or slightly lower than the transmit frequency.

RF: radio frequency

SSB: single sideband. When a carrier is amplitude modulated, both upper and lower sidebands are produced. This results in a signal that is 6 kHz wide. Since both sidebands carry the same information, and the carrier carries no information, someone figured out that if they could filter out the carrier and one of the sidebands, and put all the power into a single sideband, the efficiency of voice communications would be much greater. Nearly all voice communications on the shortwave bands now use SSB.

SWR: standing-wave ratio. The SWR of an antenna system is a measure of how closely the impedances of

the antenna and feedline match the output impedance of the transmitter.

talk group: virtual channel that connects amateur radio operators through a repeater or over the internet.

VHF: very high frequency. The range of frequencies between 30 MHz and 300 MHz.

ULS: Universal Licensing System. The FCC's Universal Licensing system contains information on all FCC licensees, including amateur radio operators. For more information, go to <http://www.fcc.gov/uls>.

UHF: ultra high frequency. The range of frequencies between 300 MHz and 3000 MHz. 41

USB: upper sideband. See **SSB**.

VFO: variable frequency oscillator. VFOs are used to control the receiving and transmitting frequencies of amateur radio equipment.

WSJT, WSJT-X: amateur radio software developed by Joe Taylor, K1JT, that supports weak-signal and low-power digital communication modes, such as JT65, JT4, JT9, and QRA64 (EME); FSK441 and JTMS (meteor scatter); JT6M and ISCAT (ionospheric scatter), and FT8 and FT4.

About the Author

I have been a licensed radio amateur since 1971 and a radio enthusiast as long as I can remember. I've been teaching amateur radio classes for the past twenty years. For more information on my classes, go to my website, <https://kb6nu.com>.

In addition to being an amateur radio instructor:

- I blog about amateur radio at KB6NU.Com (<https://kb6nu.com>).
- I have written study guides for the General Class and Extra Class exams. You can find the *No-Nonsense General Class License Study Guide* and the *No-Nonsense Extra Class License Study Guide* in PDF, Nook (ePub) and Kindle (.mobi) formats on my website at <http://www.kb6nu.com/study-guides>. It's also available in print from Amazon.
- I am the author of *21 Things to Do With your Amateur Radio License*, a book for those who have been recently licensed or are just getting back into the hobby. It's also available in PDF, Nook (ePub) and Kindle (.mobi) formats on my website at <http://www.kb6nu.com/product/21-things-to-do-after-you-get-your-amateur-radio-license-pdf/>. It's also available in print from Amazon.
- I am the author of *The CW Geek's Guide to Having Fun with Morse Code*, a book for those wanting to learn the art of Morse Code. It's also available in PDF, Nook (ePub) and Kindle (.mobi) formats on my website at <https://www.kb6nu.com/product/cw-geeks-guide-to-having-fun-with-morse-code-pdf/>. It's also available in print from Amazon.

You can contact me by sending e-mail to cwgeek@kb6nu.com. If you have comments or questions about any of the material in this book, I hope you will do so.

73!

Dan, KB6NU